

# SONOROUS<sup>®</sup> | FURNITURE

Sonorous provides audio&video related products with focus on quality, functionality and aesthetics. Founded in 2004, a solid position and reputation worldwide has been built up over the years. Now represented worldwide in more than 50 countries via strong partnerships with a global network of distributors.

Our products are engineered to meet the demanding needs of today's electronics and represent an attentive monitoring of market trends and changes. Continuous research into materials and finishes has been distinguishing characteristics of Sonorous.



# AUDIOVISUAL FURNITURE

## INDEX

### WOOD SERIES

STUDIO SERIES	8-15
RETRO SERIES	16-17
MOOD SERIES	18-23
LB SERIES	24-27
TRN & TRD SERIES	28-31

### GLASS & METAL SERIES

PL SERIES	32-45
NEO SERIES	46-53

### SOUND SYSTEMS

SOUND SYSTEMS	54-59
---------------	-------

### PRO SERIES

PRO SERIES	60-61
------------	-------

# STUDIO SERIES

- FLAP DOOR WITH PUSH TO OPEN SYSTEM
- TOP PANEL TEMPERED GLASS
- FRONT DOOR WITH GLASS, WOOD DECORS OR FABRIC
- CABINET WITH BASE OR WALL HANGING (WALL HANGING ONLY FOR ST 110-160)
- ADJUSTABLE SHELVES FOR AV EQUIPMENT (ONLY FOR ST 160-161-200)
- EASY CABLE ACCESS BETWEEN SHELVES AND SECTIONS
- HIDDEN INFRARED REPEATER SYSTEM, REMOTE CONTROL FOR COMPONENTS BEHIND CABINET DOORS
- IR FRIENDLY FRONT GLASS (ONLY AVAILABLE FOR "I" MODEL)
- OPTIONAL BRACKET (EXCEPT ST 200)
- FULLY ASSEMBLED (A) OR DISASSEMBLED (D)
- ACOUSTIC FABRIC FOR AUDIO DEVICES INCLUDING CENTER SPEAKERS, SOUNDBARS
- ACOUSTIC PERFORATED DOOR FOR AUDIO DEVICES INCLUDING CENTER SPEAKERS, SOUNDBARS (ONLY FOR ST 200)

ST 110    ST 160    ST 200    ST 261    ST 361  
 ST 111    ST 161    ST 260    ST 360    ST 362    ST 363

## BODY COLORS

WHT-WHITE



BLK-BLACK



F- FLAP  
 I- IR FRIENDLY GLASS  
 T- TEXTILE  
 P- PERFORATED(only for ST200)

## DOOR OPTIONS AND COLORS

### WOOD DECOR

CWN-CASTELLO WALNUT



VIC-VICTORIA



OAK-OAK



BNW-BLACK NORTH WOOD



GNW-GREY NORDIC WOOD



LOAK-LIGHT OAK



### PERFORATED COLORS

WHT-WHITE



BLK-BLACK



### GLASS COLORS

WHT-WHITE

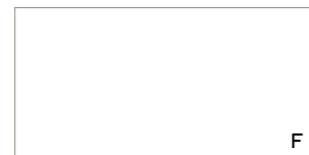

BLK-BLACK

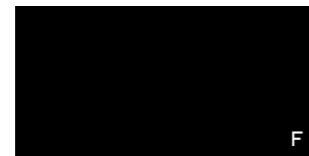

### HOW (I) GLASS LOOKS

I-BLK-BLACK



I-WHT-WHITE

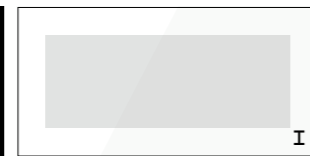

### TEXTILE

GRY-GREY



OLV-OLIVE



IRN-IRON



BLK-BLACK

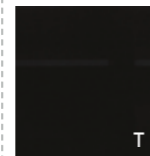

NVY-NAVY



BRD-BORDEAUX



## STA 200P-WHT-WHT-BS

- MAX TOP LOAD  
100 KG
- IDEAL SCREEN SIZE  
85"

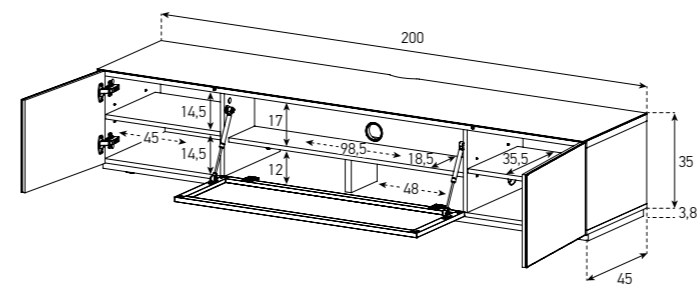





STA 360F-WHT-GNW-SL

**STA 110F-WHT-WHT-BS**

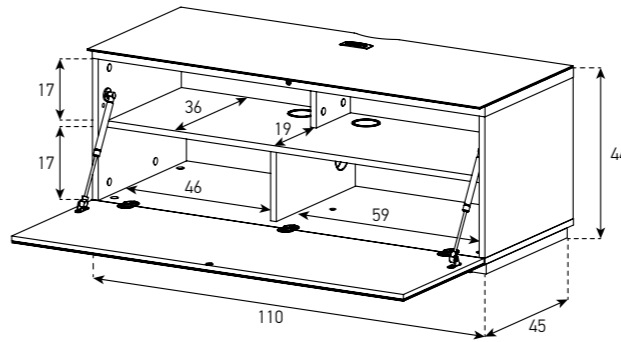
-  MAX TOP LOAD  
60 KG
-  IDEAL SCREEN SIZE  
52"



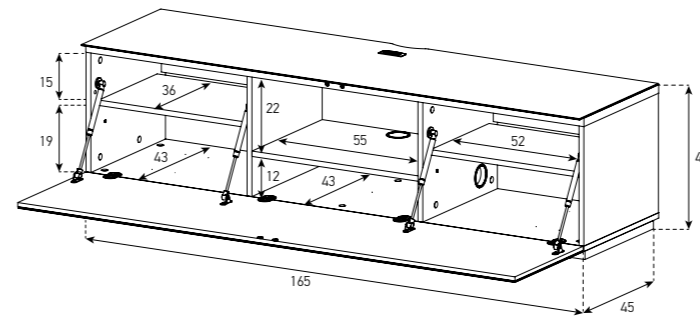

**STA 160F-BLK-CWN-BS**

-  MAX TOP LOAD  
60 KG
-  IDEAL SCREEN SIZE  
70"





STA 200P-WHT-WHT-BS

**STA 260T-WHT-BLK-BS**

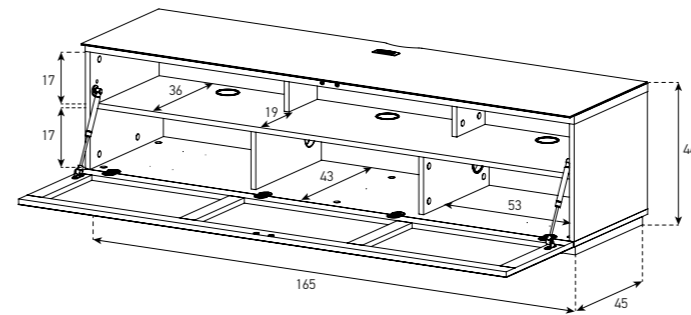
-  MAX TOP LOAD  
60 KG
-  IDEAL SCREEN SIZE  
70"



**STA 360I-WHT-WHT-SL**

-  MAX TOP LOAD  
60 KG
-  IDEAL SCREEN SIZE  
70"

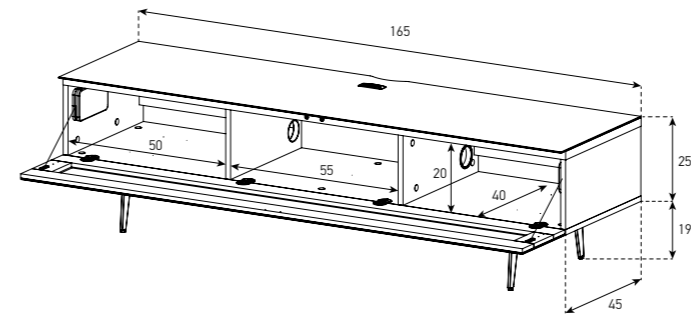



### STA 362I-WHT-BLK-SL

- MAX TOP LOAD  
60 KG
- IDEAL SCREEN SIZE  
76"

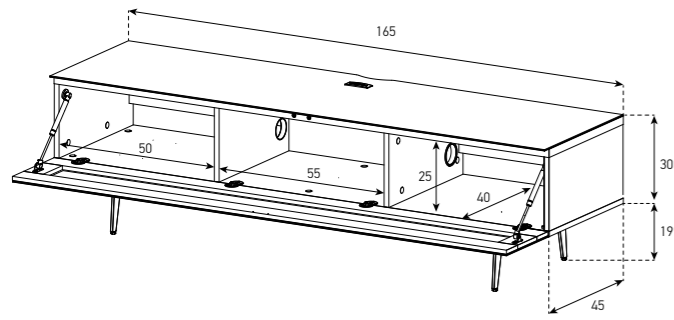

### STA 361F-BLK-BLK-SL

- MAX BRACKET LOAD  
50 KG
- IDEAL SCREEN SIZE  
68"

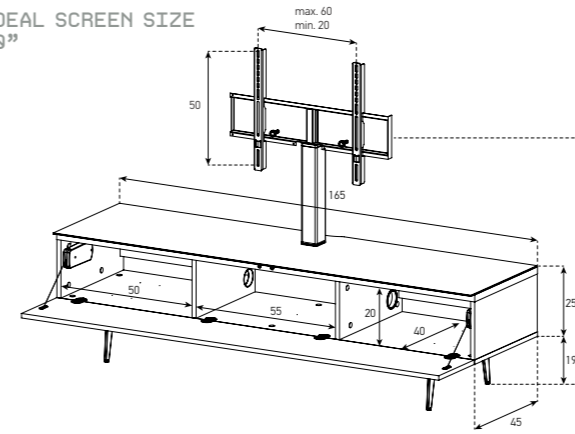

45°



### STA 111T-BLK-OLV-BS

- MAX BRACKET LOAD  
50 KG
- IDEAL SCREEN SIZE  
52"

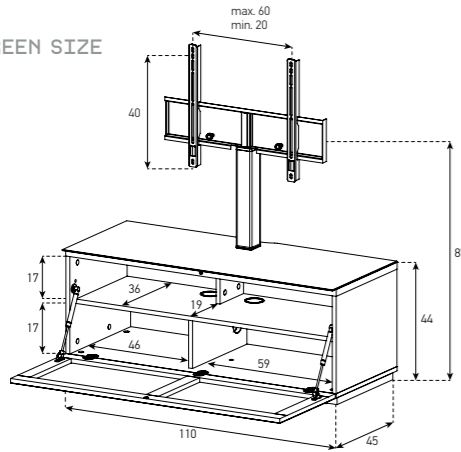

45°



### STA 363F-BLK-BNW-SL

- MAX BRACKET LOAD  
50 KG
- IDEAL SCREEN SIZE  
68"

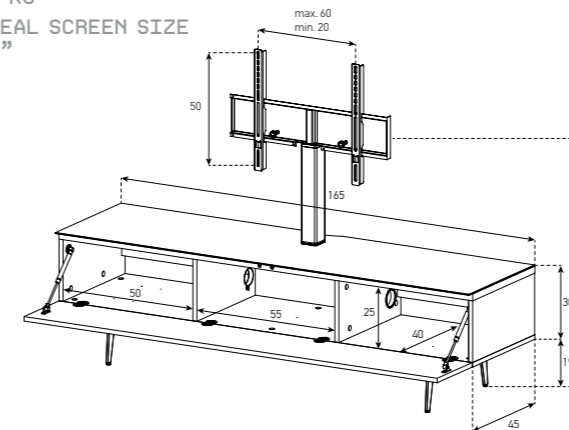

45°



### STA 161I-WHT-WHT-BS

- MAX BRACKET LOAD  
50 KG
- IDEAL SCREEN SIZE  
68"

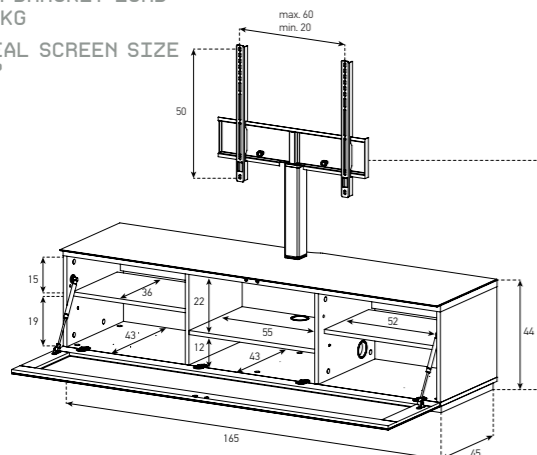

45°



### Bracket Kit ST-ADP-SLV-4060

- MAX BRACKET LOAD  
50 KG
- IDEAL SCREEN SIZE  
68"

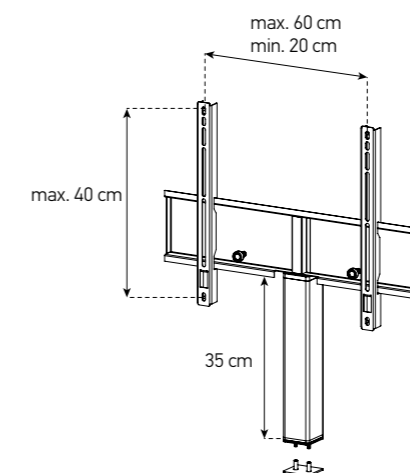

### STA 261T-BLK-BLK-BS

- MAX BRACKET LOAD  
50 KG
- IDEAL SCREEN SIZE  
68"

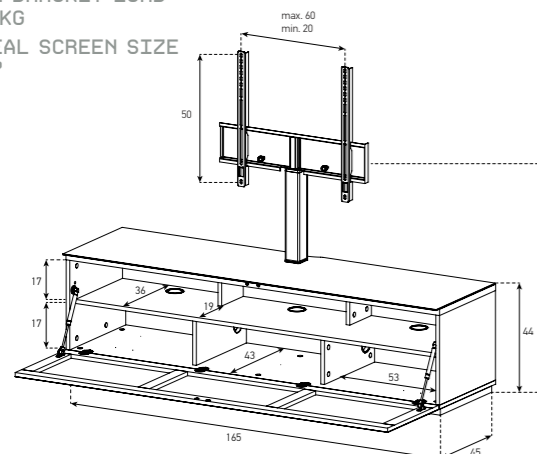

45°



### Bracket Kit ST-ADP-HBLK-5060

- MAX BRACKET LOAD  
50 KG
- IDEAL SCREEN SIZE  
68"

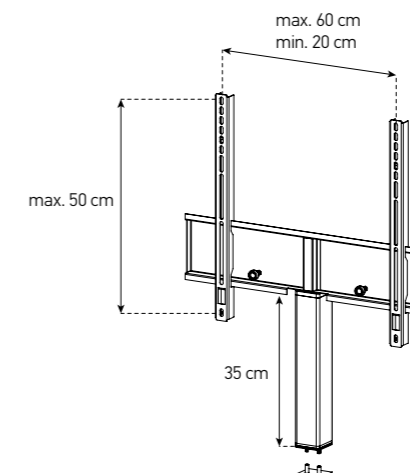

STA 110I-BLK-BLK-WL



STA 110F-BLK-BLK-BS



CODE SAMPLE

# STA 110F-WHT-WHT-BS

1 2 3 4 5 6 7

- 1- STUDIO SERIES
- 2- ASSEMBLE OPTION

- (A) - ASSEMBLED
- (D) - DISASSEMBLED

- 3- MODEL

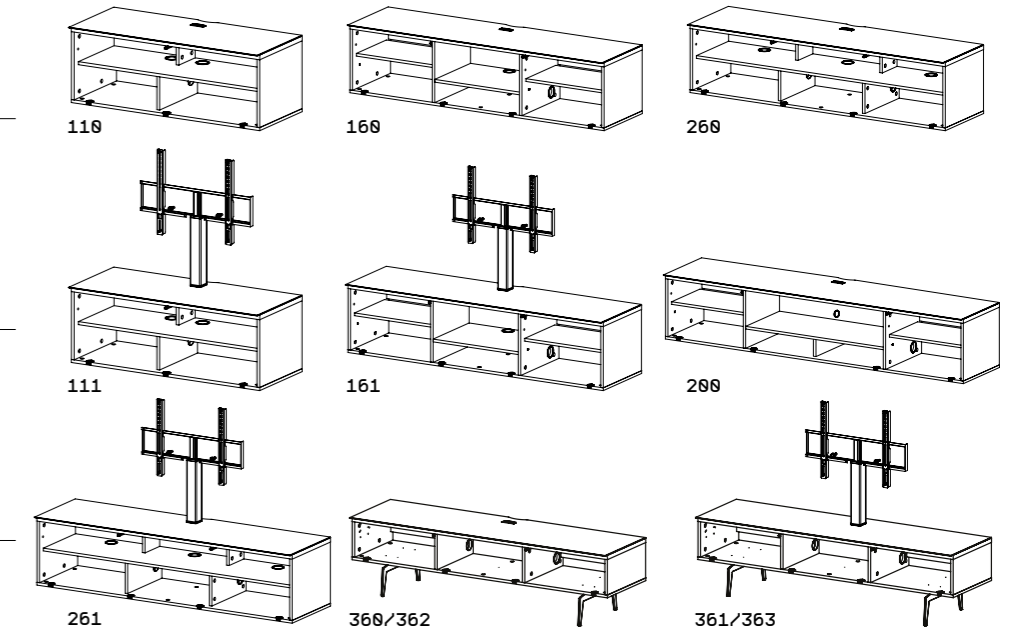

- 4- DOOR OPTION

- (F) - FLAP (NOT APPLICABLE TO 260/261 MODELS)
- (I) - IR FRIENDLY (GLASS)
- (T) - TEXTILE
- (P) - PERFORATED (ONLY FOR ST 200)

- 5- BODY COLOR

- (BLK) - BLACK
- (WHT) - WHITE

- 6- DOOR COLOR

- (WHT) - WHITE
- (BLK) - BLACK
- (GNW) - GREY NORDIC WOOD
- (CWN) - CASTELLO WALNUT
- (OAK) - OAK
- (BNW) - BLACK NORTH WOOD
- (VIC) - VICTORIA
- (LOAK) - LIGHT OAK
- (GRY) - GREY
- (OLV) - OLIVE
- (IRN) - IRON
- (BRD) - BORDEAUX
- (NYV) - NAVY

APPLICABLE DOOR  
OPTIONS

- (F) (I) (P)
- (F) (I) (T) (P)
- (F)
- (F)
- (F)
- (F)
- (F)
- (F)
- (T)
- (T)
- (T)
- (T)
- (T)

- 7- FLOOR/WALL OPTION

- (BS) - BASE
- (WL) - WALL HANGING (EXCEPT 300 SERIES AND ST 200)
- (BW) - BASE & WALL HANGING
- (SL) - STEEL LEGS (ONLY AVAILABLE FOR 300 SERIES)



# RETRO SERIES

- Contemporary design to complement your décor
- Sturdy construction to support large screen TVs up to 70"
- Dimensions: 140/180 cm X 54 cm X 40 cm
- Max. Top load : 60 kg
- Optimum dimension to accommodate your AV equipment
- Conical solid wood feet
- Two sliding doors with several uni-decor colors
- Cable management system
- Adjustable shelves to optimize spaces for AV equipments



RTR 140  
RTR 180

## BODY COLORS

BLK-BLACK



WHT-WHITE



VIC-VICTORIA



## DOOR COLORS

GBLK-GLOSSY BLACK



CWN-CASTELLO WALNUT



OAK-OAK



GWHT-GLOSSY WHITE



BNW-BLACK NORTH WOOD



LOAK-LIGHT OAK

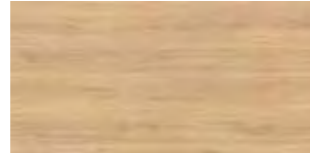

VIC-VICTORIA



GNW-GREY NORDIC WOOD

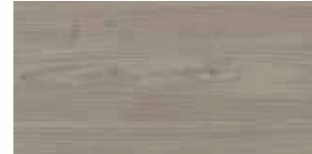

## RTR 140-BLK-BNW



MAX TOP LOAD  
60 KG



IDEAL SCREEN SIZE  
60"

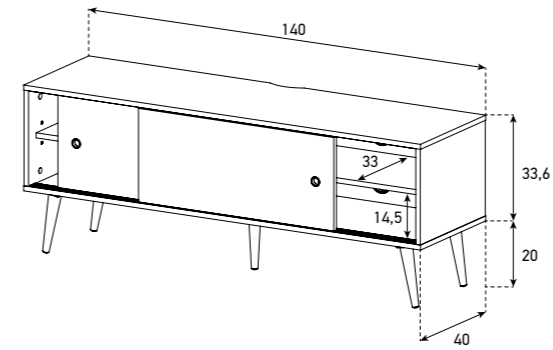

## RTR 180-WHT-VIC



MAX TOP LOAD  
60 KG



IDEAL SCREEN SIZE  
70"

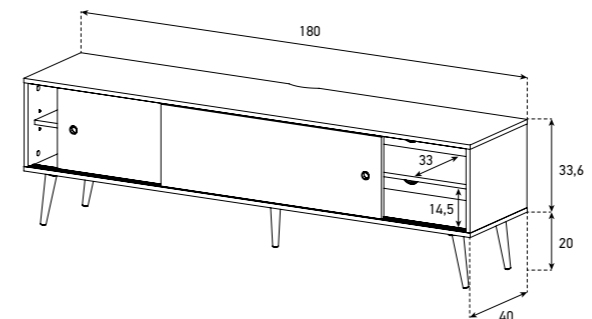



# MOOD SERIES

- TEMPERED GLASS WITH FLAT POLISHED EDGE
- ANODIZED OR POWDER COATED ALUMINIUM PROFILES IN BACK COLUMN AND LEGS
- MELAMINE FACED WOOD OR NON-SCRATCH HIGH GLOSS FINISHING CABINETS
- CABINET FLAP FOR A/V EQUIPMENT
- CABINET FLAP FOR DVD HOLDER
- CABINET DRAWER WITH "SILENT STOP"
- INTEGRATED CABLE MANAGEMENT SYSTEM
- HIDDEN CASTERS
- (24°) SWIVEL SYSTEM
- ADJUSTABLE HEIGHT FOR BRACKET (+/- 75 MM)

MD 8140    MD 8340    MD 9140    MD 9540  
 MD 8143    MD 8540    MD 9240  
 MD 8240    MD 9135    MD 9340

## GLASS COLORS

C-CLEAR



B-BLACK



## WOOD FINISHING

BLK-BLACK



CWN-CASTELLO WALNUT



VIC-VICTORIA



## ALUMINIUM FINISHING

INX-INOX



HBLK-HIGH GLOSS BLACK

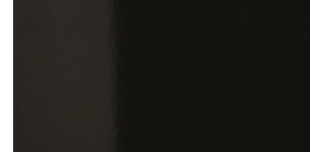

WHT-WHITE



GNW-GREY NORDIC WOOD

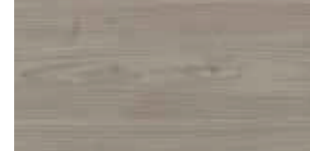

BNW-BLACK NORTH WOOD

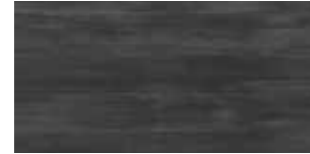

OAK-OAK



LOAK-LIGHT OAK



RED-RED

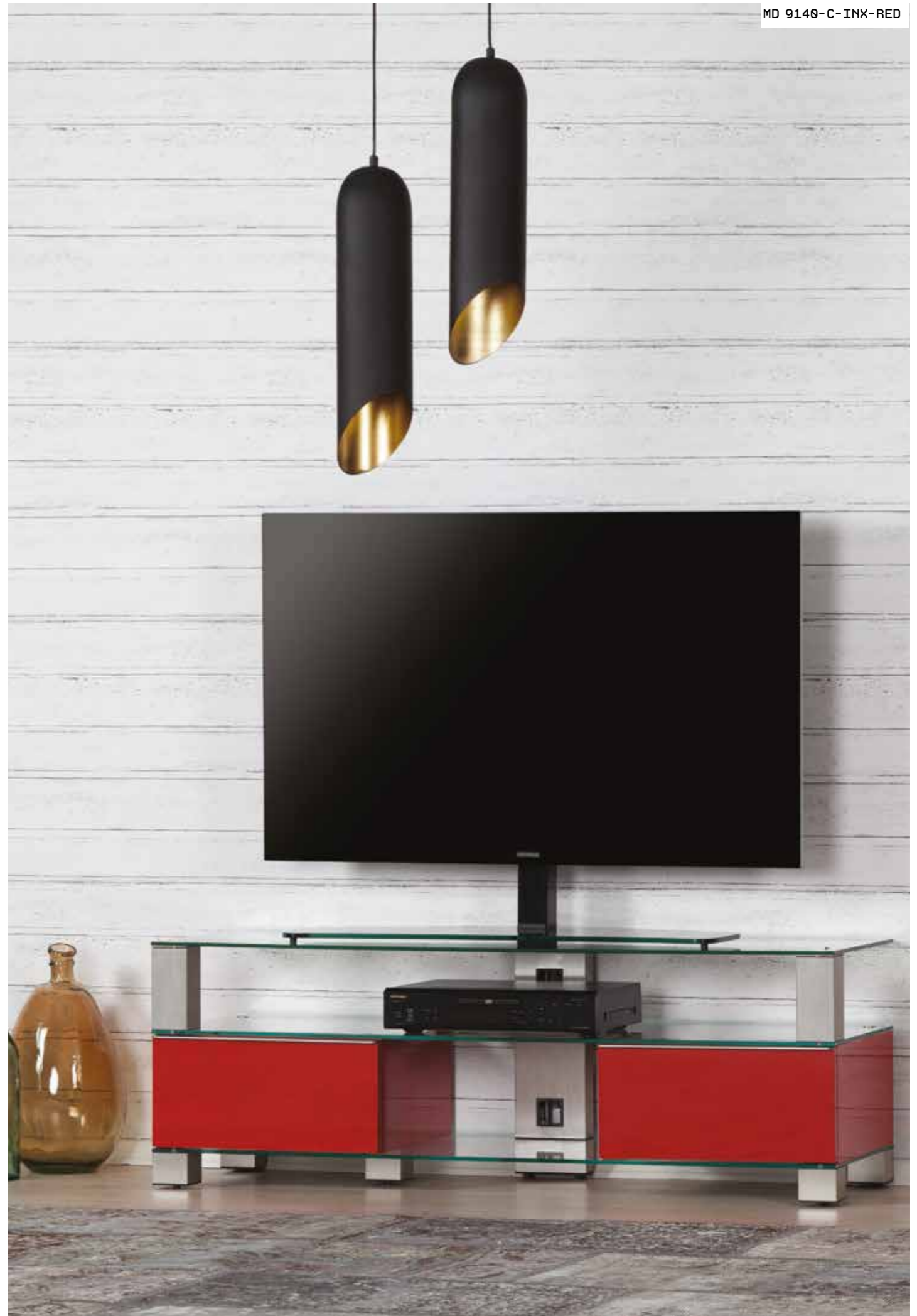

### MD 8140-C-INX-WHT

- MAX BRACKET LOAD  
50 KG
- IDEAL SCREEN SIZE  
60"

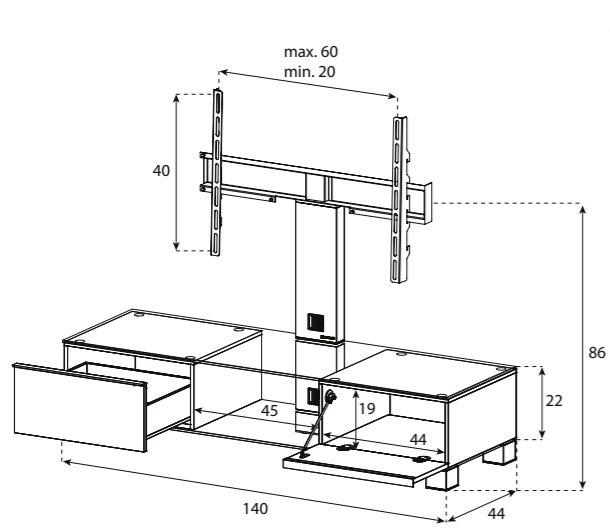

### MD 8340-B-INX-BLK

- MAX BRACKET LOAD  
50 KG
- IDEAL SCREEN SIZE  
60"

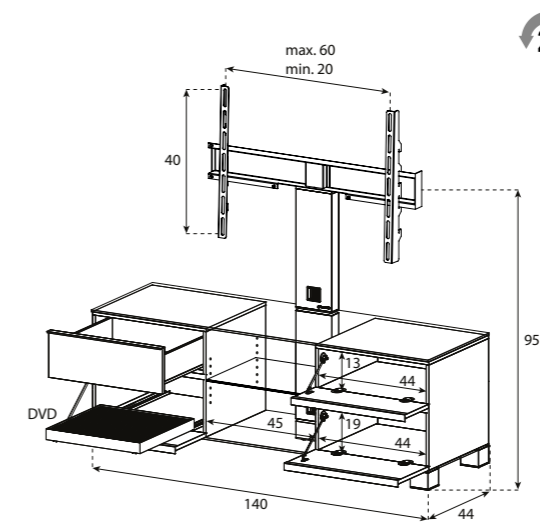

### MD 8143-B-HBLK-BLK

- MAX BRACKET LOAD  
50 KG
- IDEAL SCREEN SIZE  
60"

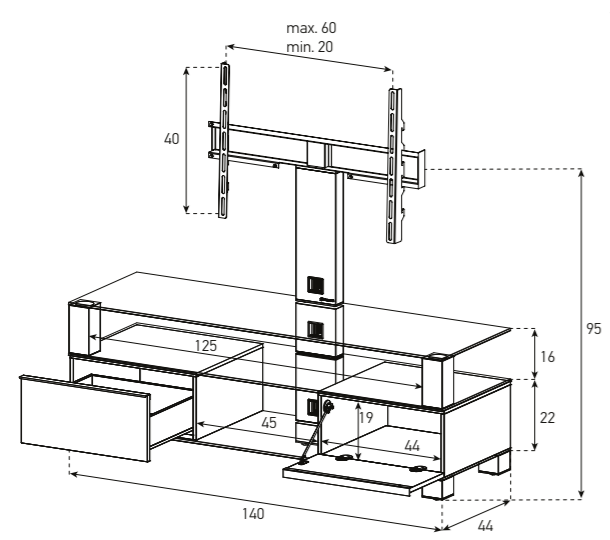

### MD 8240-C-INX-RED

- MAX BRACKET LOAD  
50 KG
- IDEAL SCREEN SIZE  
60"

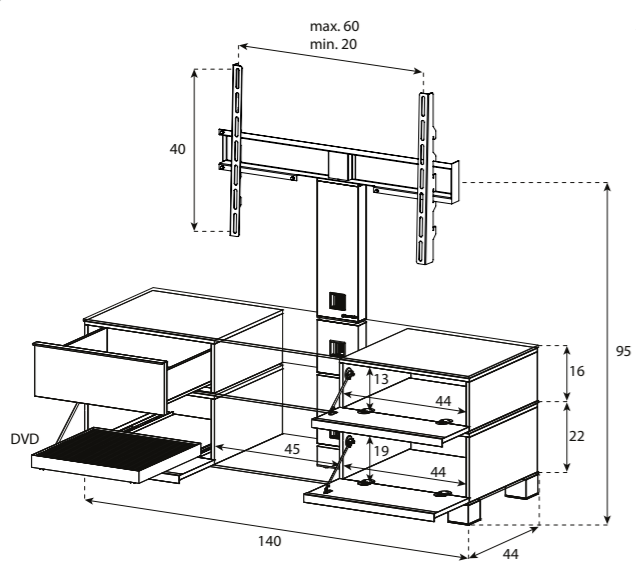

MD 8240-C-INX-WHT



### MD 8540-B-INX-GNW

- MAX BRACKET LOAD  
50 KG
- IDEAL SCREEN SIZE  
60"

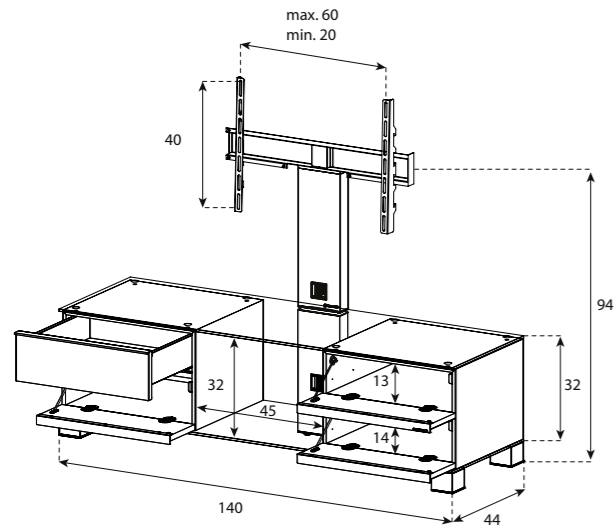

### MD 9340-B-INX-BNW

- MAX TOP LOAD  
80 KG
- IDEAL SCREEN SIZE  
60"

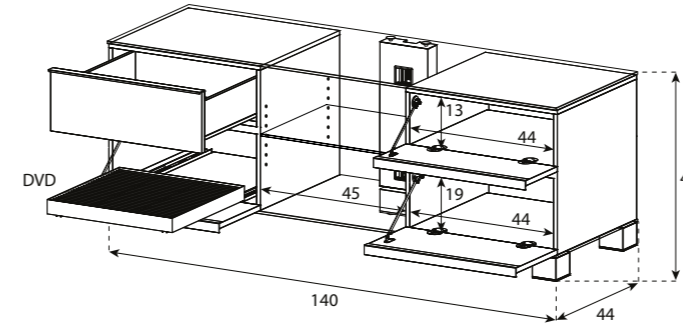

### MD 9140-B-HBLK-LOAK

- MAX TOP LOAD  
80 KG
- IDEAL SCREEN SIZE  
60"

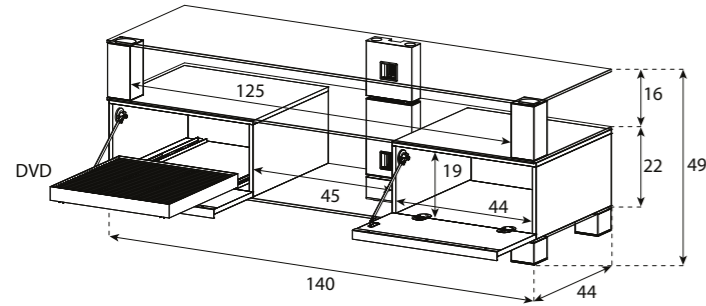

### MD 9135-B-HBLK-BLK

- MAX TOP LOAD  
50 KG
- IDEAL SCREEN SIZE  
50"

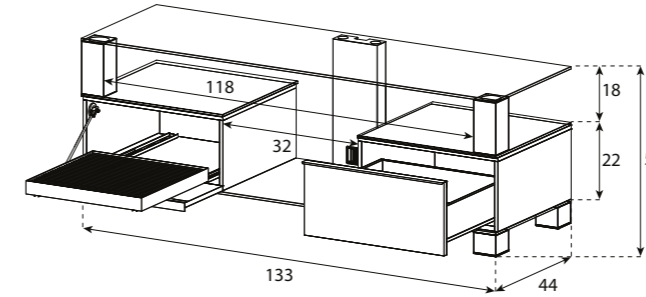

### MD 9240-B-INX-LOAK

- MAX TOP LOAD  
80 KG
- IDEAL SCREEN SIZE  
60"

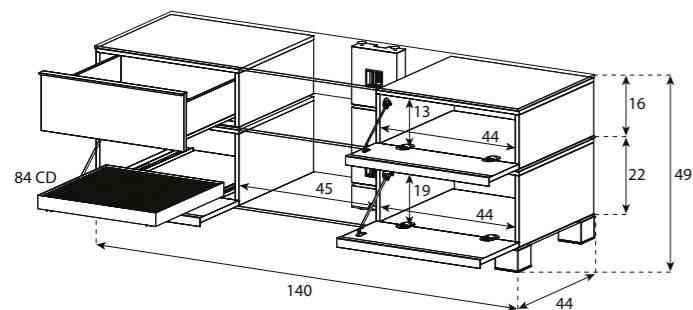

### MD 9540-B-INX-CWN

- MAX TOP LOAD  
80 KG
- IDEAL SCREEN SIZE  
60"

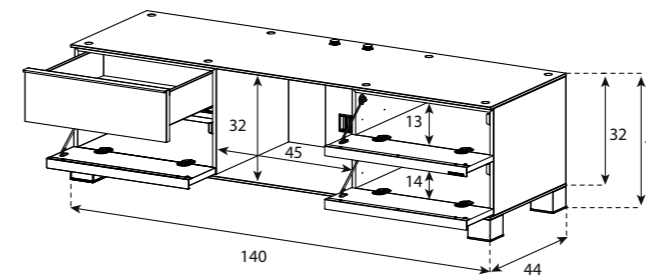

# LB SERIES

## LB 1620 / LB 1621

TOP PANEL COVERED WITH BLACK TEMPERED GLASS OR WALNUT WOOD DECOR  
 TEMPERED GLASS FRONT DOORS, REMOTE CONTROL WORKS THROUGH  
 REMOVABLE MIDDLE SHELVES  
 MIDDLE DOOR COVERED WITH FABRIC (ONLY FOR LB 1621)  
 SHELVES FOR AV EQUIPMENT / SUBWOOFER  
 HIDDEN CASTERS

## LB 1123 / LB 2120

BLACK TEMPERED GLASS  
 DRAWERS WITH PUSH TO OPEN SYSTEM  
 HIDDEN CASTERS

## LB 1840 / 1540 / 1181

BLACK TOP PANEL COVERED WITH BLACK TEMPERED GLASS  
 GLOSSY AND WOOD DECOR FRONT DOORS  
 REMOVABLE MIDDLE SHELVES  
 DRAWERS WITH PUSH TO OPEN SYSTEM

LB 1123<sup>2</sup>    LB 1620<sup>4</sup>    LB 2120<sup>2</sup>  
 LB 1181<sup>4</sup>    LB 1621<sup>4</sup>  
 LB 1540<sup>3</sup>    LB 1840<sup>3</sup>

### GLASS COLORS

#### B-BLACK



### BODY COLORS

#### BLK-BLACK



#### GBLK-GLOSSY BLACK



### DOOR COLORS

#### GBLK-GLOSSY BLACK



#### GWHT-GLOSSY WHITE



#### CWN-CASTELLO WALNUT



#### OAK-OAK



#### GNW-GREY NORDIC WOOD

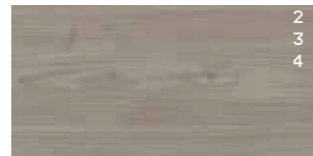

#### VIC-VICTORIA



#### LOAK-LIGHT OAK



#### BNW-BLACK NORTH WOOD

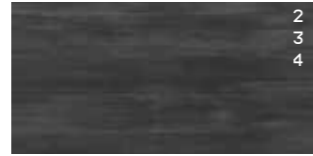



### LB 1123-B-BLK-GBLK

- MAX BRACKET LOAD  
40 KG
- IDEAL SCREEN SIZE  
50"

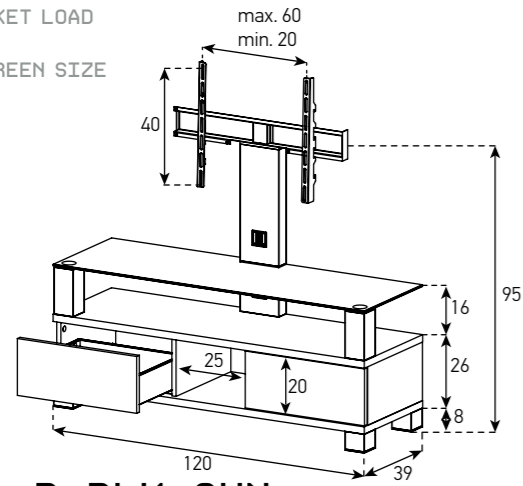

24°



### LB 1181-B-BLK-CWN

- MAX TOP LOAD  
40 KG
- IDEAL SCREEN SIZE  
50"

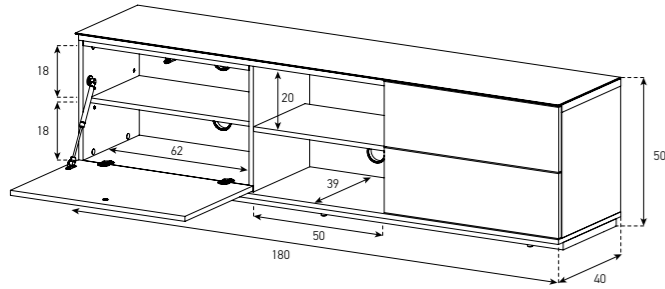

### LB 1540-B-BLK-OAK

- MAX TOP LOAD  
40 KG
- IDEAL SCREEN SIZE  
50"

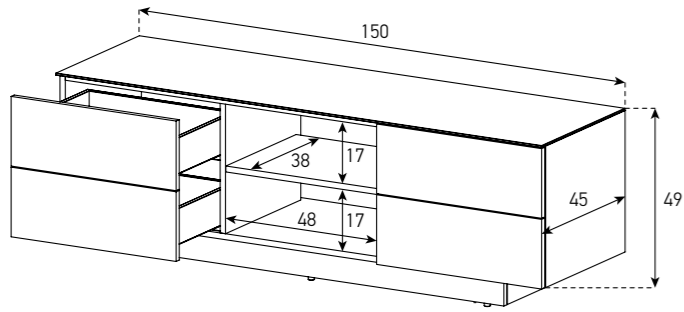

### LB 1620-B-BLK

- MAX TOP LOAD  
80 KG
- IDEAL SCREEN SIZE  
70"

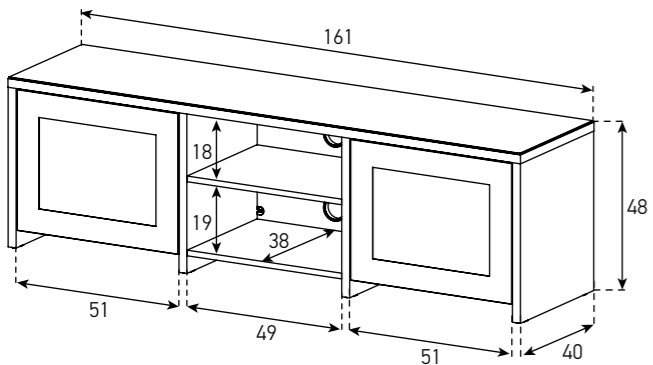

### LB 1621-B-BLK

- MAX TOP LOAD  
80 KG
- IDEAL SCREEN SIZE  
70"

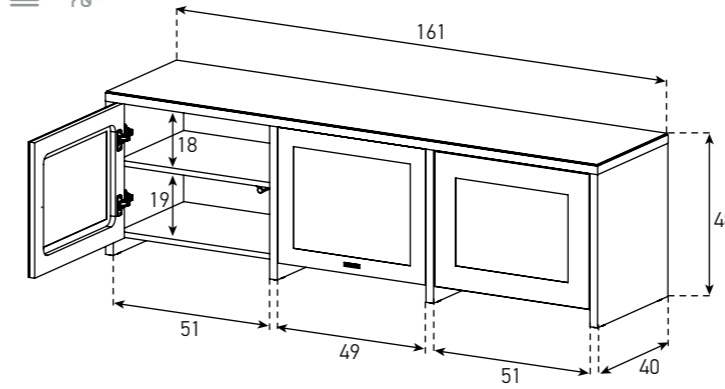

### LB 1840-GBLK-GWHT

- MAX TOP LOAD  
80 KG
- IDEAL SCREEN SIZE  
70"

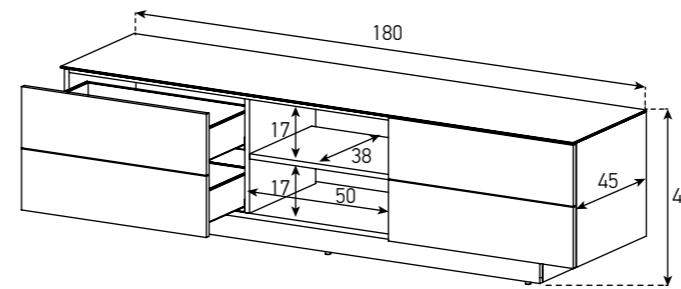

### LB 2120-B-BLK-GBLK

- MAX TOP LOAD  
50 KG
- IDEAL SCREEN SIZE  
50"

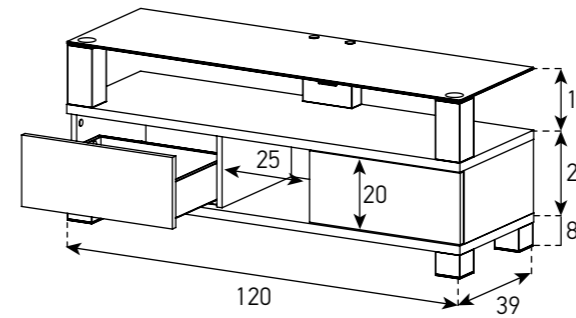

# TRN & TRD SERIES

## TRN

TOP PANEL BLACK TEMPERED GLASS  
WOOD CABINET WITH FLAP DOOR AND/OR DRAWERS  
HIDDEN CASTORS  
SHELVES FOR A/V EQUIPMENTS

## TRD

WOOD CABINET WITH FLAP DOWN OR SIDE OPENING DOORS  
SHELVES FOR A/V EQUIPMENTS

TRN 1113<sup>1</sup>  
TRN 1133<sup>1</sup>  
TRN 2110<sup>1</sup>  
TRN 2130<sup>1</sup>

TRD 90<sup>2</sup>  
TRD 100<sup>2</sup>  
TRD 120<sup>2</sup>  
TRD 150<sup>2</sup>



TRN 1113-B-BLK-LOAK

## GLASS COLORS

### B-BLACK



## ALUMINIUM FINISHING

### SLV-SILVER



### HBLK-HIGH GLOSS BLACK



## BODY COLORS

### BLK-BLACK

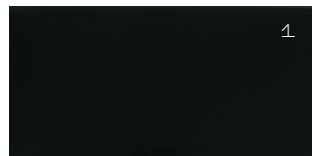

### GWHT-GLOSSY WHITE



### GBLK-GLOSSY BLACK

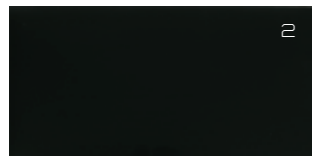

## DOOR COLORS

### GBLK-GLOSSY BLACK

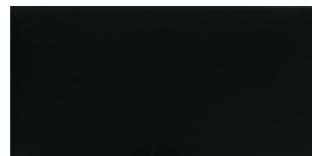

### VIC-VICTORIA



### CWN-CASTELLO WALNUT



### GWHT-GLOSSY WHITE



### OAK-OAK



### LOAK-LIGHT OAK



### BNW-BLACK NORTH WOOD

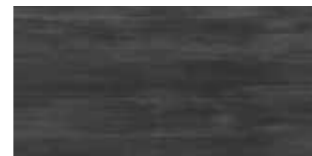

### GNW-GREY NORDIC WOOD



TRD 150-GBLK-GWHT

### TRN 1113-B-BLK-GWHT

- MAX BRACKET LOAD  
50 KG
- IDEAL SCREEN SIZE  
46"

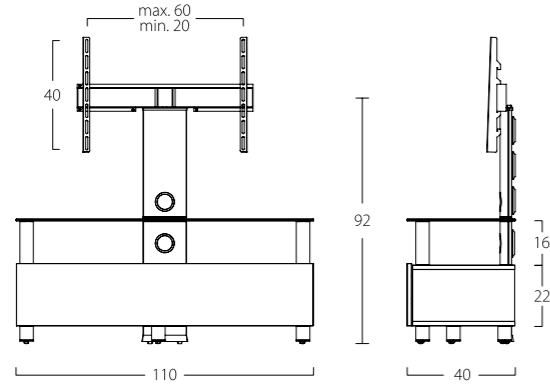

### TRD 90-GBLK-VIC

- MAX LOAD  
50 KG
- IDEAL SCREEN SIZE  
42"

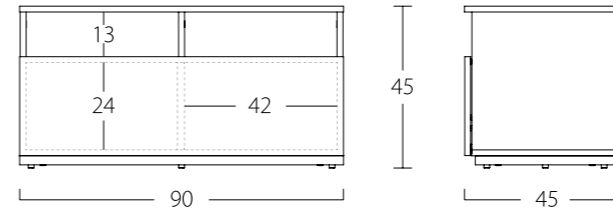

### TRN 1133-B-BLK-GNW

- MAX BRACKET LOAD  
50 KG
- IDEAL SCREEN SIZE  
55"

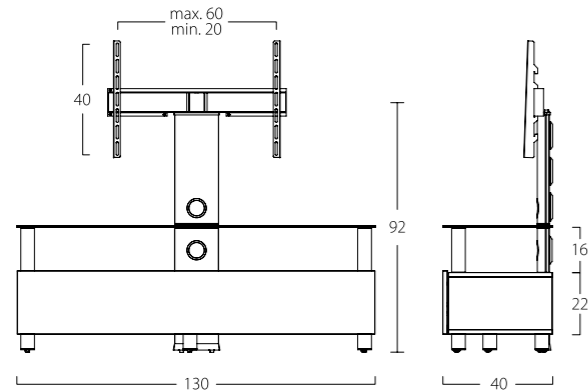

### TRD 100-GBLK-OAK

- MAX LOAD  
50 KG
- IDEAL SCREEN SIZE  
50"

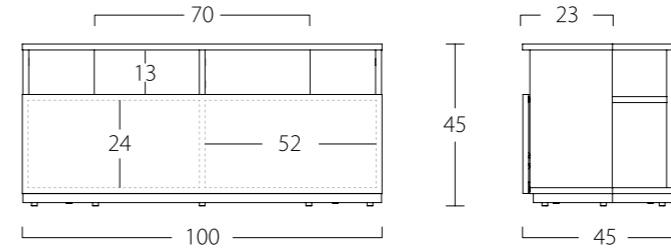

### TRN 2110-B-BLK-BNW

- MAX LOAD  
50 KG
- IDEAL SCREEN SIZE  
46"

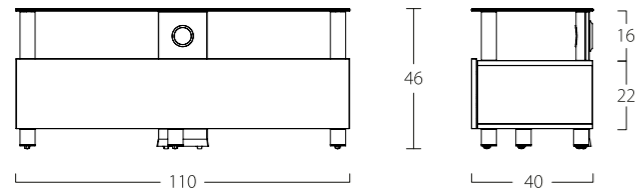

### TRD 120-GBLK-CWN

- MAX LOAD  
50 KG
- IDEAL SCREEN SIZE  
55"

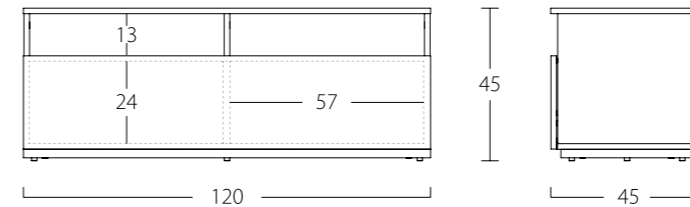

### TRN 2130-B-BLK-CWN

- MAX LOAD  
50 KG
- IDEAL SCREEN SIZE  
55"

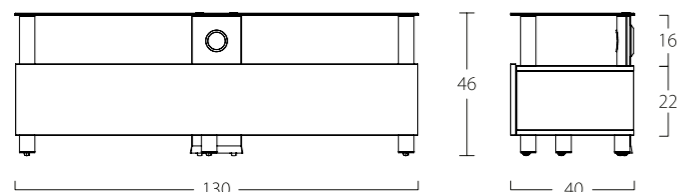

### TRD 150-GWHT-LOAK

- MAX LOAD  
50 KG
- IDEAL SCREEN SIZE  
60"

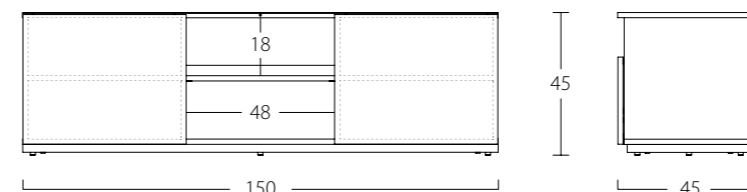



# PL SERIES

- TEMPERED GLASS WITH FLAT POLISHED EDGE
- ELLIPTICAL OR RECTANGLE SHAPED ALUMINIUM
- INTEGRATED CABLE MANAGEMENT SYSTEM
- HIDDEN CASTERS
- SWIVEL SYSTEM
- ADJUSTABLE HEIGHT FOR BRACKET

PL 2000<sup>4</sup> PL 2335<sup>4</sup> PL 2500<sup>3</sup> PL 2611<sup>4</sup> PL 2810<sup>2</sup> PL 3400<sup>3</sup>  
 PL 2100<sup>4</sup> PL 2344<sup>4</sup> PL 2510<sup>3</sup> PL 2620<sup>4</sup> PL 3100<sup>4</sup> PL 3405<sup>3</sup>  
 PL 2130<sup>4</sup> PL 2345<sup>4</sup> PL 2511<sup>3</sup> PL 2700<sup>1</sup> PL 3110<sup>4</sup> PL 3410<sup>3</sup>  
 PL 2200<sup>4</sup> PL 2400<sup>3</sup> PL 2515<sup>3</sup> PL 2710<sup>1</sup> PL 3115<sup>4</sup> PL 3415<sup>3</sup>  
 PL 2310<sup>4</sup> PL 2430<sup>3</sup> PL 2610<sup>4</sup> PL 2800<sup>2</sup> PL 3150<sup>4</sup>

## ALUMINIUM COLORS

### SLV-SILVER



### HBLK-HIGH GLOSS BLACK



### INX-INOX



## GLASS COLORS

### C-CLEAR



### B-PIANOBLACK



### WHT-WHITE



### RED-RED



## PL2700-PL2710-PL2800-PL2810 GLASS COLOR OPTIONS

### BLK-BLACK

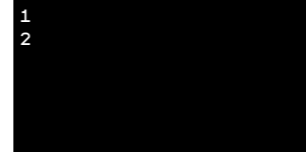

### GRP-GRAPHITE

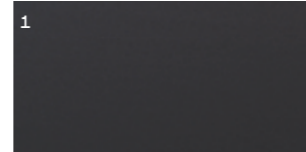



### PL 2000-C-SLV

- MAX BRACKET LOAD  
60 KG
- IDEAL SCREEN SIZE  
60"

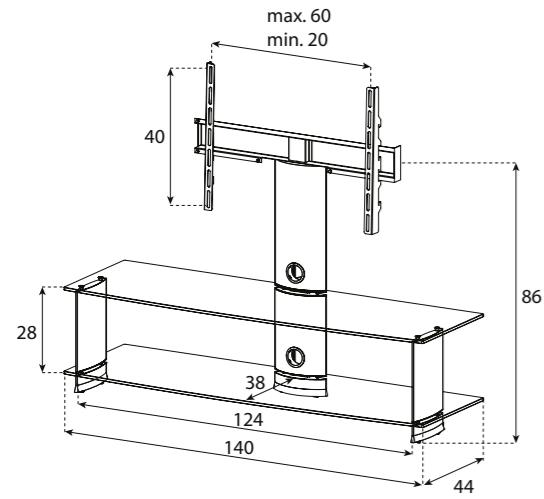

35°



### PL 2100-B-SLV

- MAX BRACKET LOAD  
50 KG
- IDEAL SCREEN SIZE  
50"

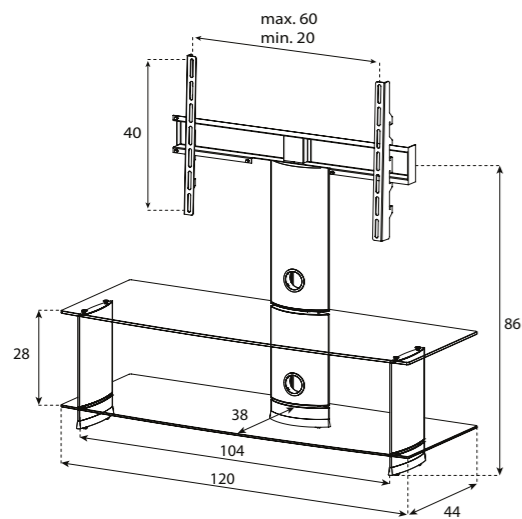

35°



### PL 2130-B-HBLK

- MAX BRACKET LOAD  
50 KG
- IDEAL SCREEN SIZE  
50"

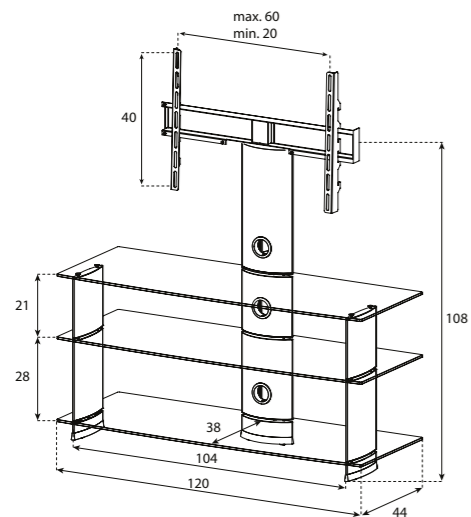

35°



### PL 2200-B-SLV

- MAX BRACKET LOAD  
30 KG
- IDEAL SCREEN SIZE  
40"

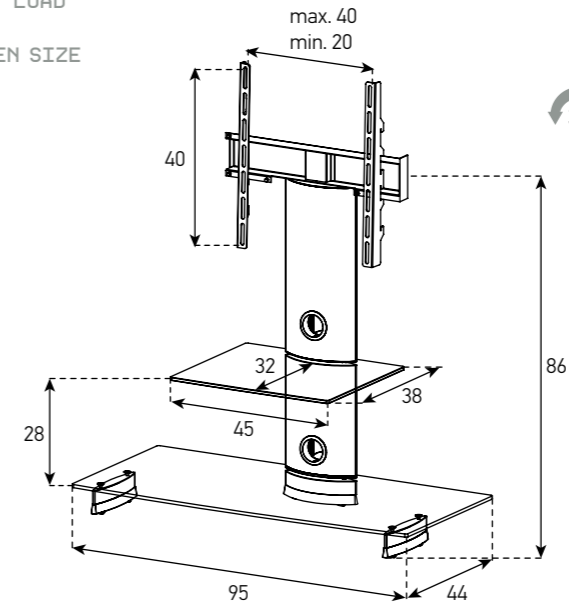

35°



### PL 2400-B-INX

- MAX BRACKET LOAD  
50 KG
- IDEAL SCREEN SIZE  
50"

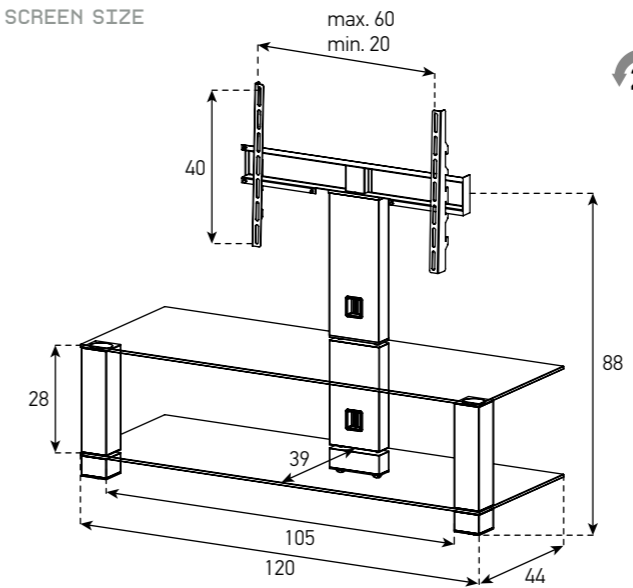

24°



### PL 2430-B-INX

- MAX BRACKET LOAD  
50 KG
- IDEAL SCREEN SIZE  
50"

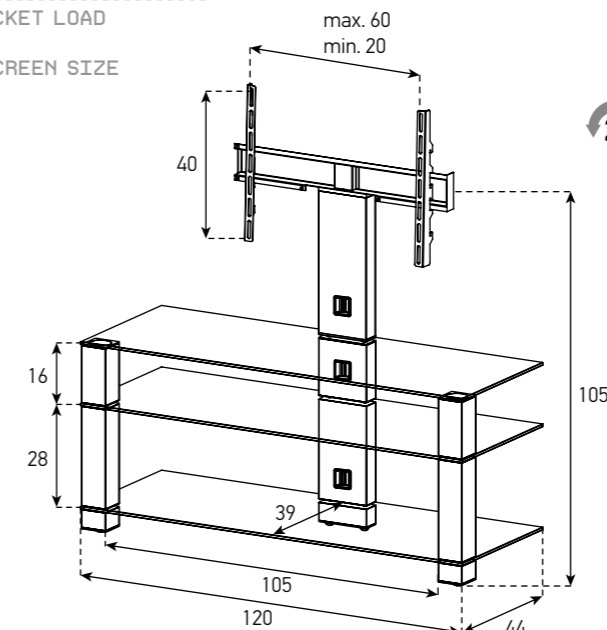

24°



### PL 2310-C-SLV

MAX BRACKET LOAD  
50 KG

IDEAL SCREEN SIZE  
50"

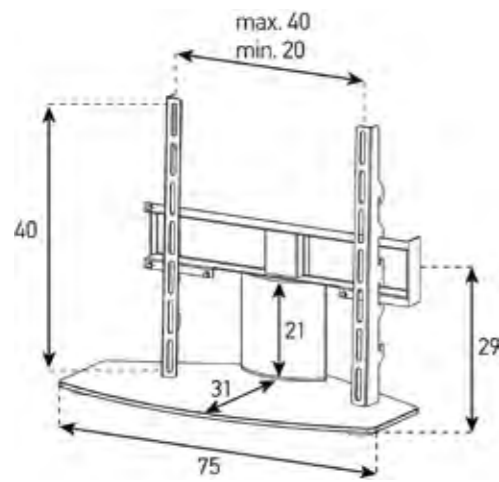

35°



### PL 2335-B-HBLK

MAX BRACKET LOAD  
40 KG

IDEAL SCREEN SIZE  
60"

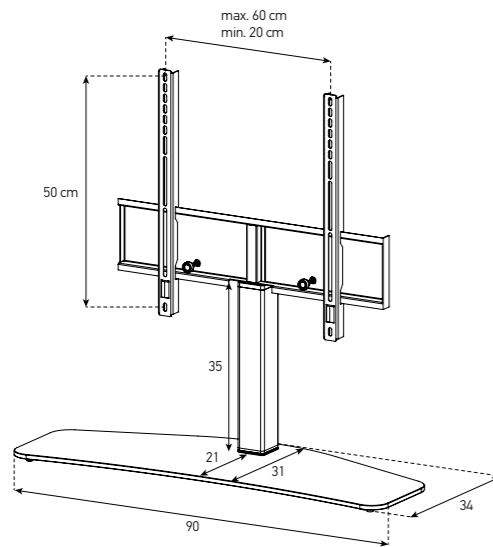

45°



### PL 2344-B-HBLK

MAX BRACKET LOAD  
50 KG

IDEAL SCREEN SIZE  
50"

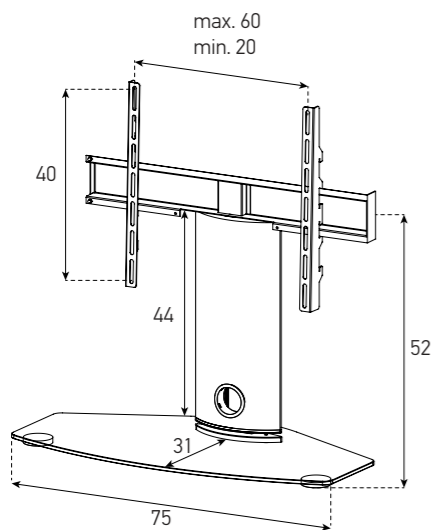

35°



### PL 2345-B-HBLK

MAX BRACKET LOAD  
40 KG

IDEAL SCREEN SIZE  
60"

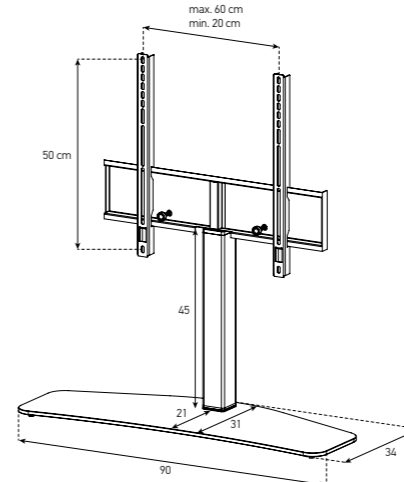

45°



### PL 2500-B-INX

MAX BRACKET LOAD  
30 KG

IDEAL SCREEN SIZE  
40"

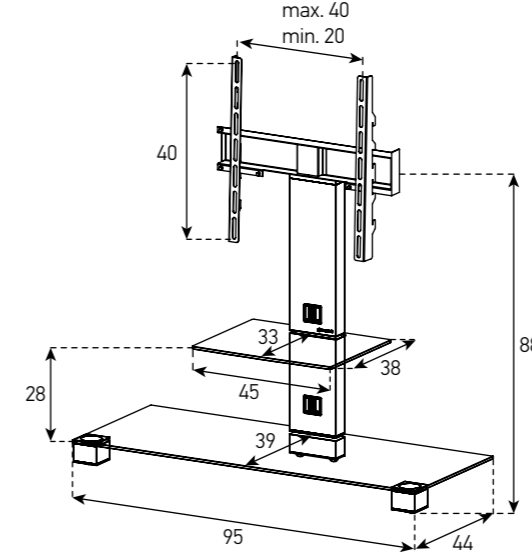

24°



### PL 2510-B-INX

MAX BRACKET LOAD  
50 KG

IDEAL SCREEN SIZE  
60"

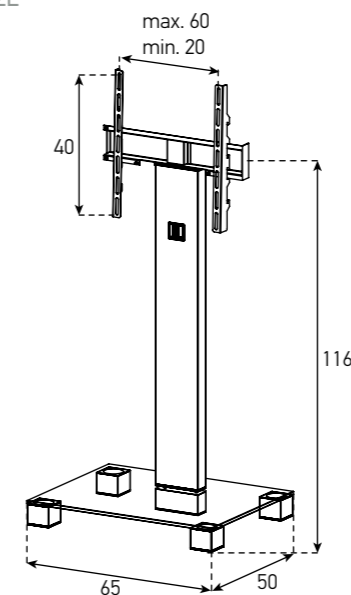

24°



### PL 2511-C-INX

- MAX BRACKET LOAD 50 KG
- IDEAL SCREEN SIZE 50"

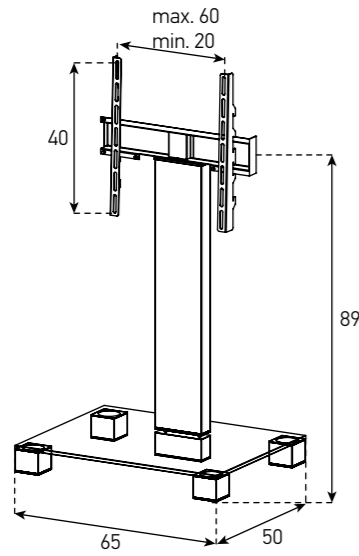

### PL 2710-BLK-INX

- MAX BRACKET LOAD 30 KG
- IDEAL SCREEN SIZE 55"

- GLASS COLOR OPTIONS  
 WHT-WHITE  
 BLK-BLACK  
 RED-RED  
 GRP-GRAPHITE

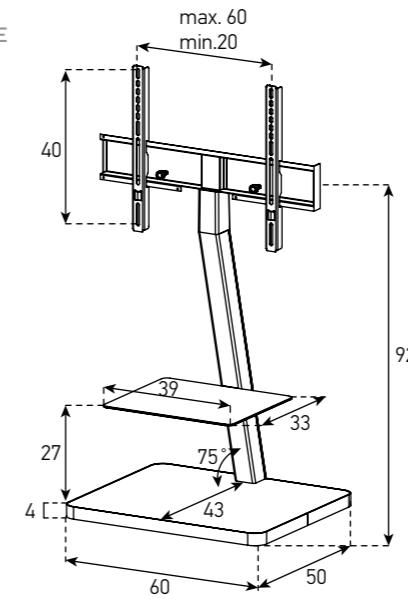

### PL 2515-B-HBLK

- MAX BRACKET LOAD 50 KG
- IDEAL SCREEN SIZE 50"

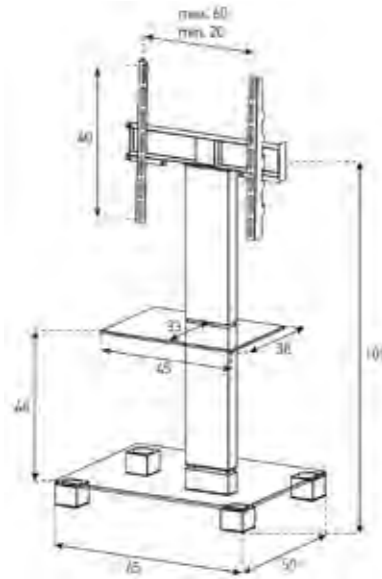

### PL 2700-BLK-INX

- MAX BRACKET LOAD 30 KG
- IDEAL SCREEN SIZE 55"

- GLASS COLOR OPTIONS  
 WHT-WHITE  
 BLK-BLACK  
 RED-RED  
 GRP-GRAPHITE

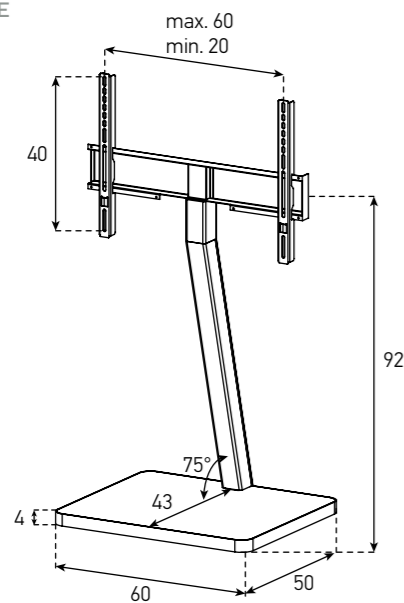

PL 2700-BLK-INX







PL 2710-BLK-INX

### PL 2810-BLK

-  MAX BRACKET LOAD  
30 KG
-  IDEAL SCREEN SIZE  
55"
- GLASS COLOR OPTIONS  
WHT-WHITE  
BLK-BLACK

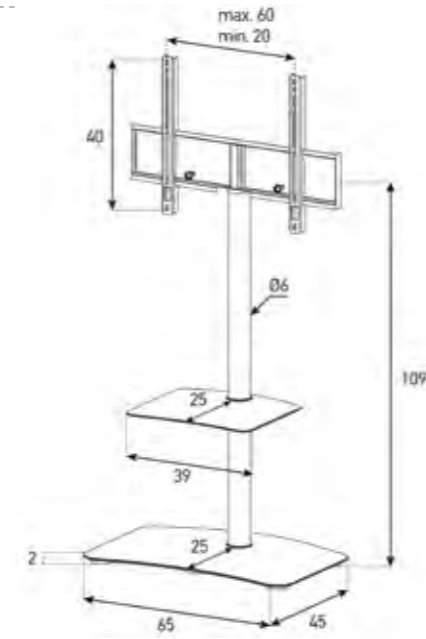

45°



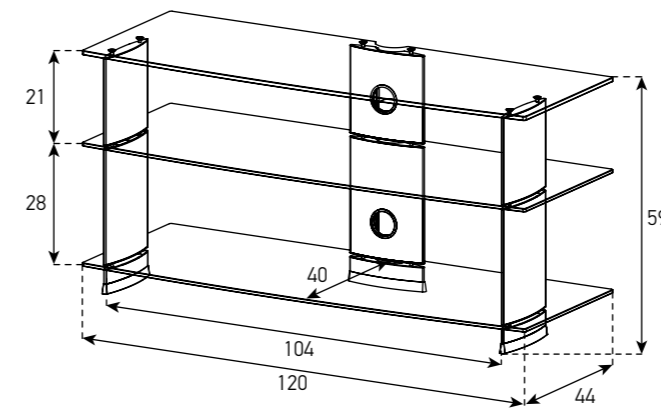

### PL 3100-B-SLV

-  MAX TOP LOAD  
50 KG
-  IDEAL SCREEN SIZE  
50"



### PL 2800-WHT

-  MAX BRACKET LOAD  
30 KG
-  IDEAL SCREEN SIZE  
55"
- GLASS COLOR OPTIONS  
WHT-WHITE  
BLK-BLACK

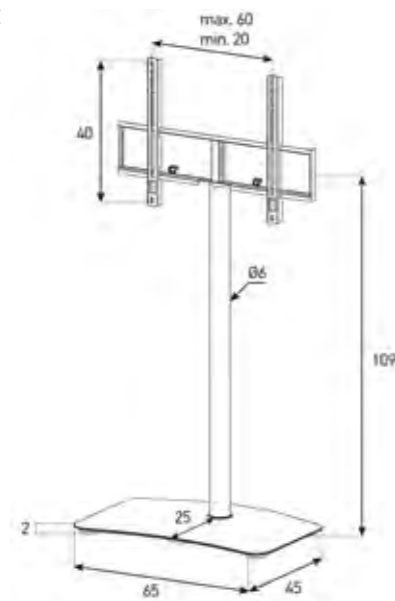

45°



### PL 3110-B-SLV

-  MAX TOP LOAD  
50 KG
-  IDEAL SCREEN SIZE  
50"

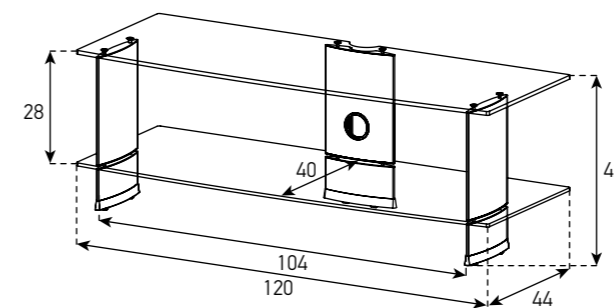



### PL 3115-B-HBLK

- MAX TOP LOAD  
40 KG
- IDEAL SCREEN SIZE  
40"

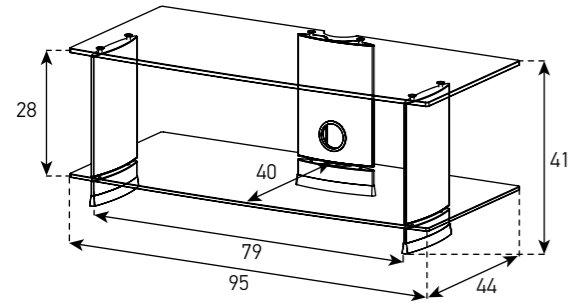

### PL 3405-C-INX

- MAX TOP LOAD  
40 KG
- IDEAL SCREEN SIZE  
40"

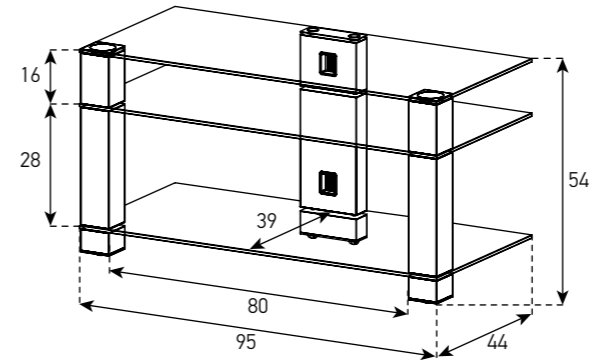

### PL 3150-C-SLV

- MAX TOP LOAD  
60 KG
- IDEAL SCREEN SIZE  
60"

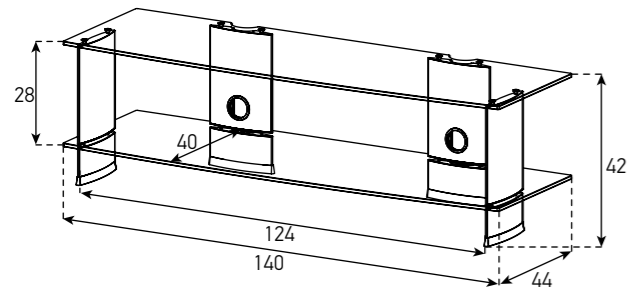

### PL 3410-B-HBLK

- MAX TOP LOAD  
50 KG
- IDEAL SCREEN SIZE  
50"

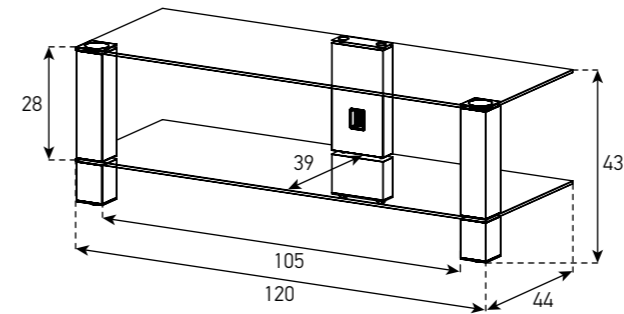

### PL 3400-B-INX

- MAX TOP LOAD  
50 KG
- IDEAL SCREEN SIZE  
50"

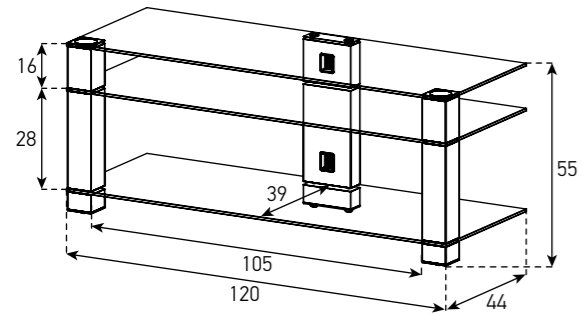

### PL 3415-C-INX

- MAX TOP LOAD  
40 KG
- IDEAL SCREEN SIZE  
40"

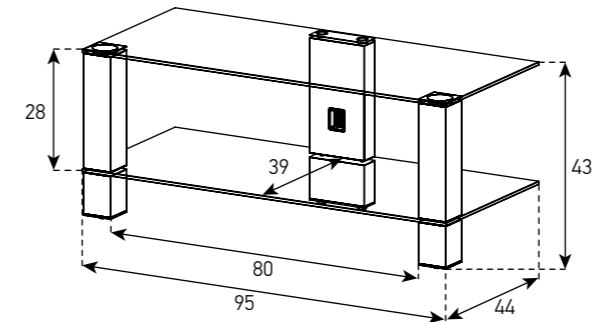

### PL 2610-B-BLK

 MAX SHELF LOAD  
5 KG

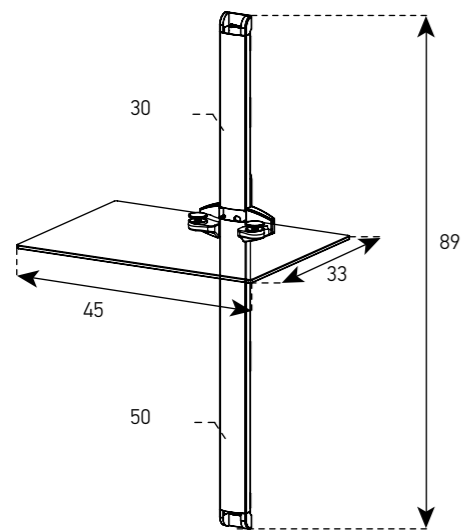

### PL 2611-BLK

 MAX LOAD  
5 KG

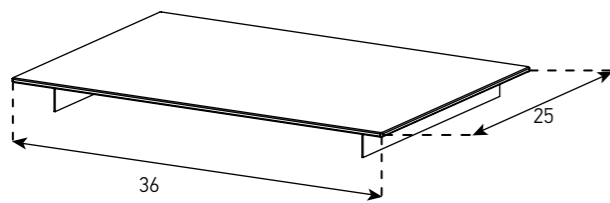

### PL 2620-B-SLV

 MAX SHELF LOAD  
5 KG

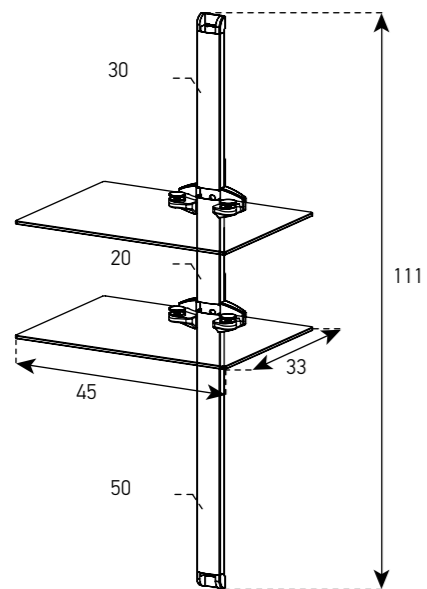

PL 2620-B-SLV



# NEO SERIES

## SPECIFICATIONS

- TEMPERED GLASS WITH FLAT POLISHED EDGE
- CYLINDRICAL AND ELLIPTICAL SHAPED ALUMINIUM PROFILES
- INTEGRATED CABLE MANAGEMENT SYSTEM
- HIDDEN CASTERS

NEO 270	NEO 370	NEO 80	NEO 95	NEO 953
NEO 290	NEO 390	NEO 81	NEO 110	NEO 1103
NEO 2110	NEO 3110	NEO 803	NEO 130	NEO 1303
	NEO 3130			

### GLASS COLORS

C-CLEAR

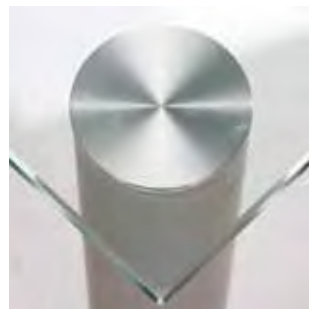

B-BLACK

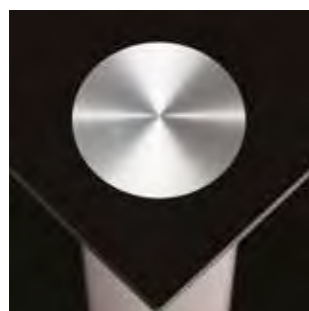

### ALUMINIUM COLORS

SLV-SILVER



HBLK-HIGH GLOSS BLACK





### NEO 270-C-SLV

- MAX TOP LOAD  
50 KG
- IDEAL SCREEN SIZE  
32"

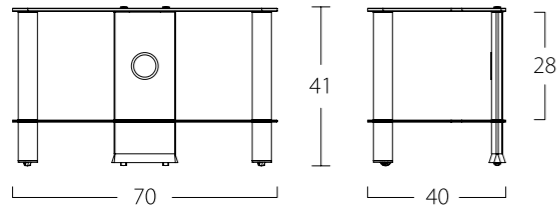

### NEO 370-B-SLV

- MAX TOP LOAD  
50 KG
- IDEAL SCREEN SIZE  
32"

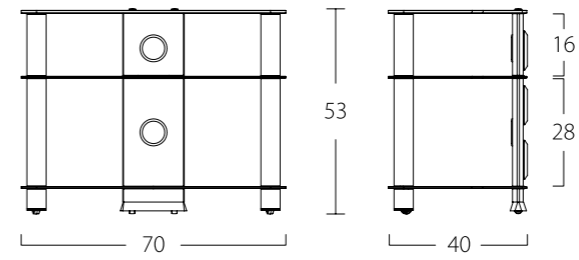

### NEO 290-B-HBLK

- MAX TOP LOAD  
50 KG
- IDEAL SCREEN SIZE  
40"

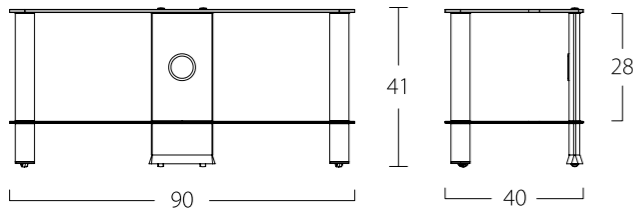

### NEO 390-B-HBLK

- MAX TOP LOAD  
50 KG
- IDEAL SCREEN SIZE  
40"

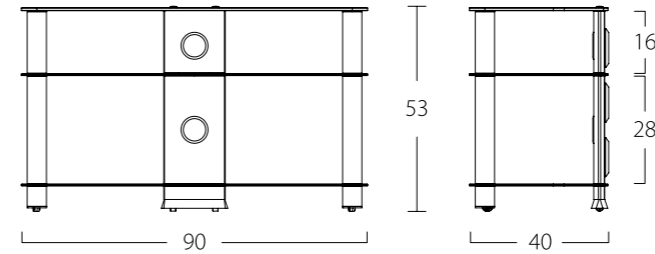

### NEO 2110-B-SLV

- MAX TOP LOAD  
50 KG
- IDEAL SCREEN SIZE  
46"

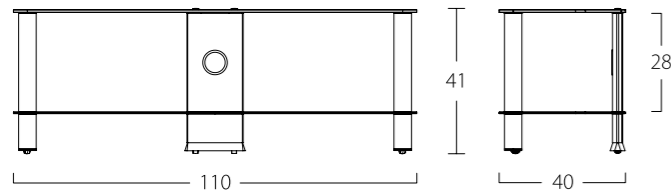

### NEO 3110-B-HBLK

- MAX TOP LOAD  
50 KG
- IDEAL SCREEN SIZE  
46"

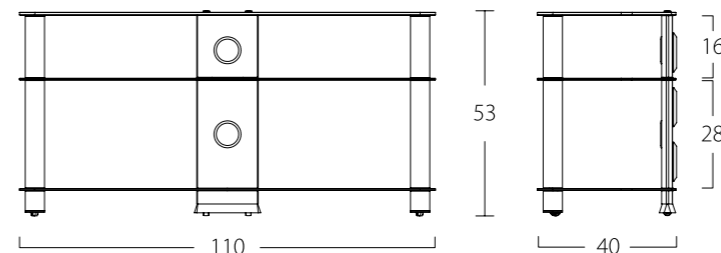

### NEO 3130-B-HBLK

- MAX TOP LOAD  
50 KG
- IDEAL SCREEN SIZE  
55"

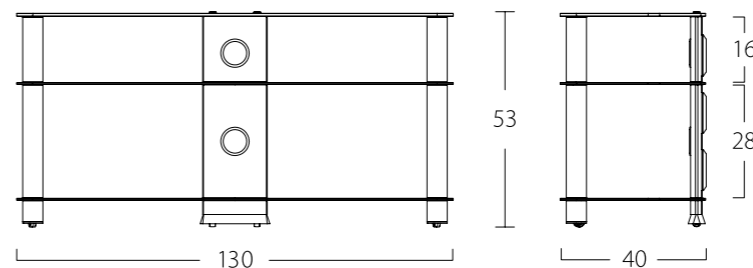

### NEO 80-B-SLV

- MAX BRACKET LOAD 30 KG
- IDEAL SCREEN SIZE 32"

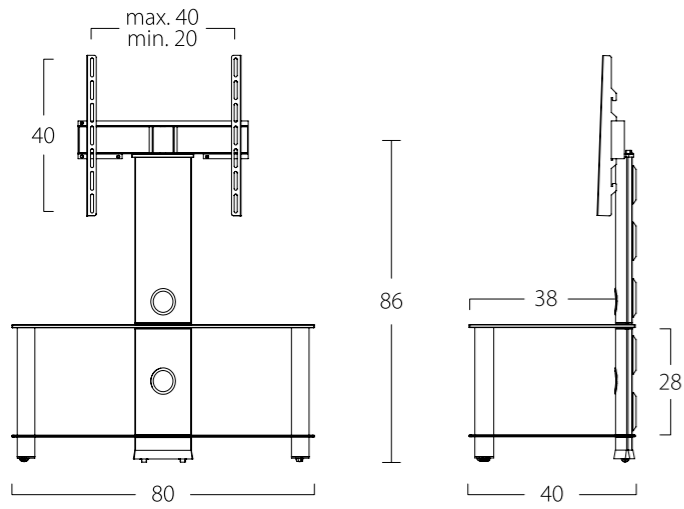

### NEO 81-C-SLV

- MAX BRACKET LOAD 30 KG
- IDEAL SCREEN SIZE 32"

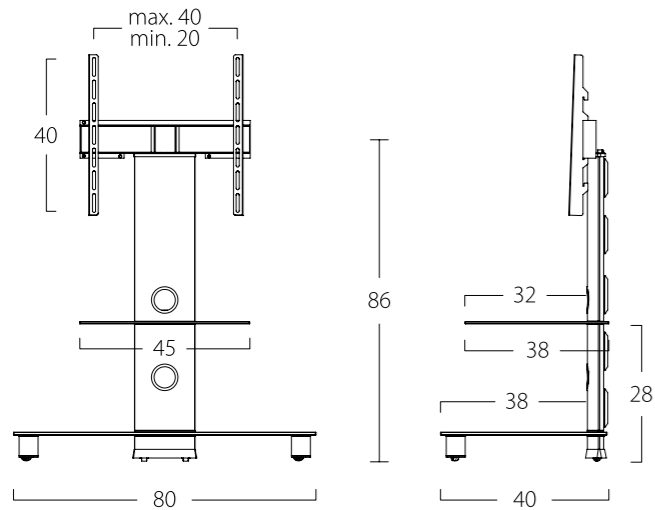

### NEO 803-B-SLV

- MAX BRACKET LOAD 40 KG
- IDEAL SCREEN SIZE 32"

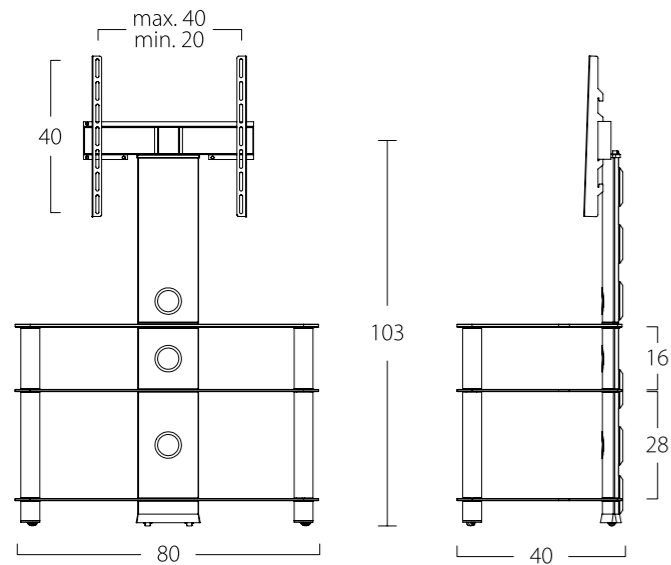

### NEO 95-B-HBLK

- MAX BRACKET LOAD 40 KG
- IDEAL SCREEN SIZE 40"

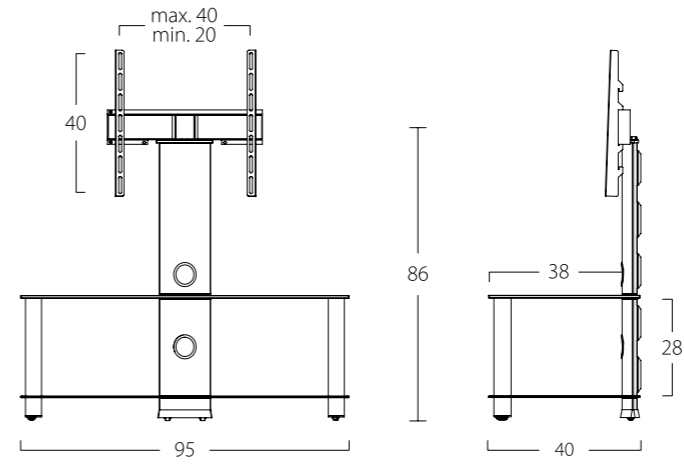

### NEO 110-C-SLV

- MAX BRACKET LOAD 40 KG
- IDEAL SCREEN SIZE 46"

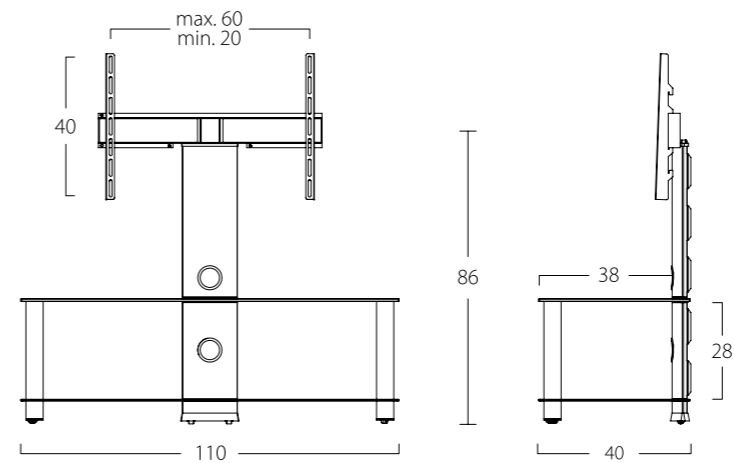

### NEO 130-B-SLV

- MAX BRACKET LOAD 40 KG
- IDEAL SCREEN SIZE 55"

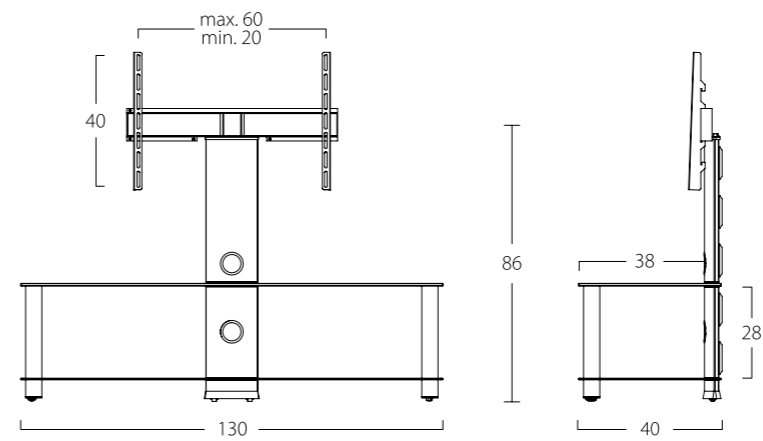

### NEO 953-B-SLV

MAX BRACKET LOAD  
40 KG

IDEAL SCREEN SIZE  
40"

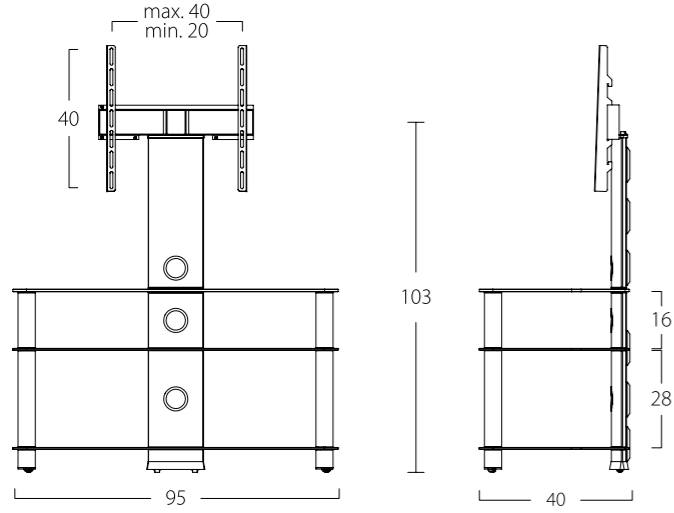

### NEO 1103-B-SLV

MAX BRACKET LOAD  
40 KG

IDEAL SCREEN SIZE  
46"

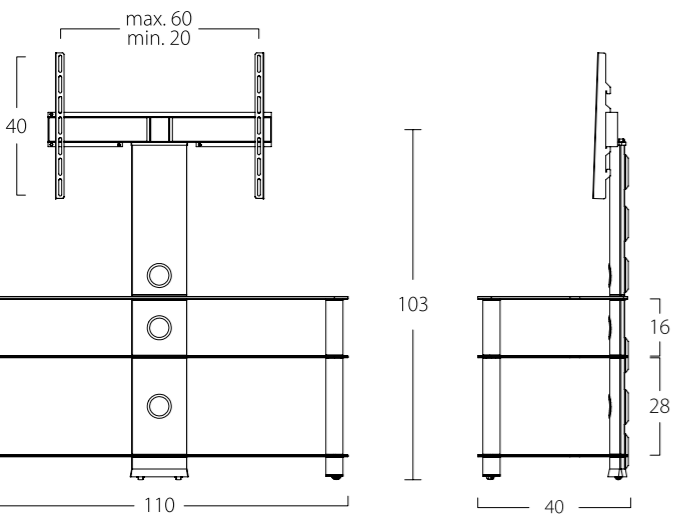

### NEO 1303-B-BLK

MAX BRACKET LOAD  
40 KG

IDEAL SCREEN SIZE  
55"

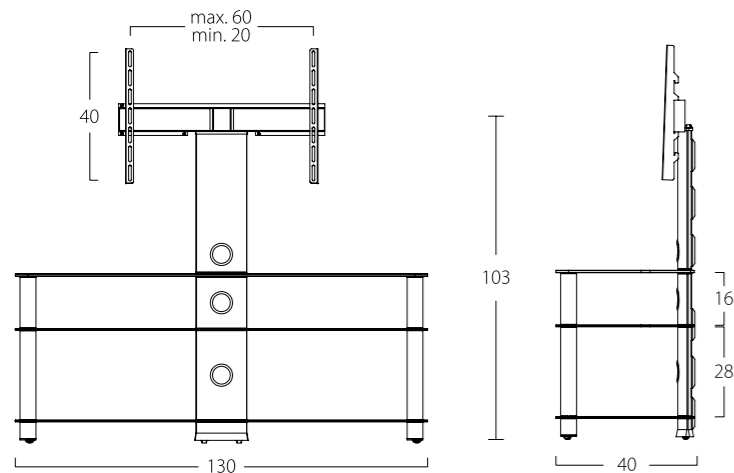



# SOUND SYSTEMS

## ROXY

TEMPERED GLASS WITH FLAT POLISHED EDGE  
 Ø 60 MM AND ELLIPTICAL SHAPED ALUMINIUM  
 SQUARE SHAPED ALUMINIUM AND HIDDEN WHEELS FOR RX 5040  
 INTEGRATED CABLE MANAGEMENT SYSTEM (NOT AVAILABLE FOR RX 5040)

## SPEAKER

UNIVERSAL COMPATIBILITY  
 ADJUSTABLE HEIGHT (FOR SP 300)

RX 2130      SP 100<sup>1</sup>  
 RX 2140      SP 200  
 RX 2150      SP 300  
 RX 5040<sup>2</sup>    SP 500  
 RX 6040<sup>3</sup>    SP 600

### ALUMINIUM COLORS

SLV-SILVER



HBLK-HIGH GLOSS BLACK

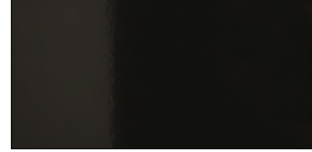

INX-INOX



### GLASS COLORS

C-CLEAR



B-PIANOBLACK



WHT-WHITE



### WOOD COLORS

VIC-VICTORIA



### METAL COLORS

BLK-BLACK



WHT-WHITE



RX 2140-C-SLV  
 SP 100-BLK



RX 5040-B-INX  
 SP 100-BLK

### RX 2130-B-HBLK

MAX TOP LOAD  
40 KG

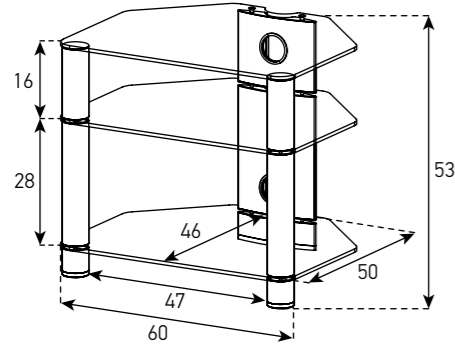

### RX 2140-B-SLV

MAX TOP LOAD  
40 KG

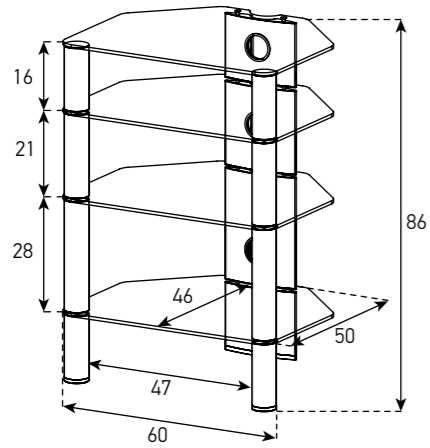

### RX 2150-C-SLV

MAX TOP LOAD  
40 KG

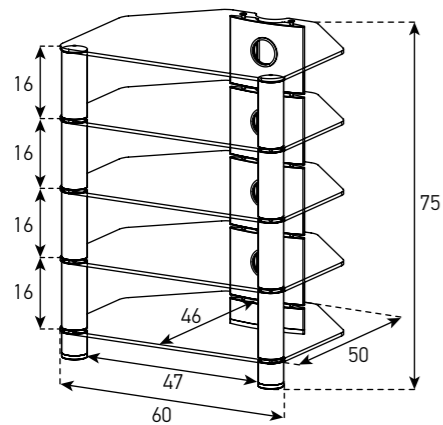

### RX 5040-B-INX

MAX TOP LOAD  
40 KG

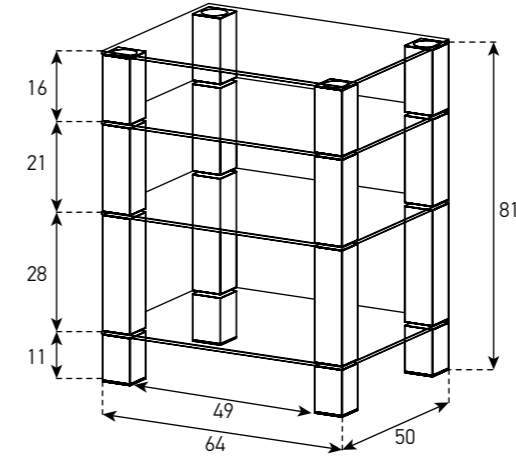

### RX 5040-VIC-HBLK

MAX TOP LOAD  
40 KG

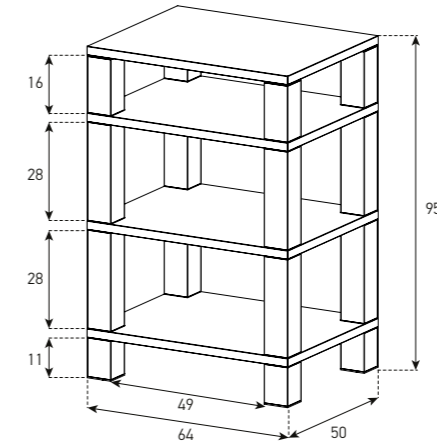

### RX 6040-B-HBLK

MAX TOP LOAD  
40 KG

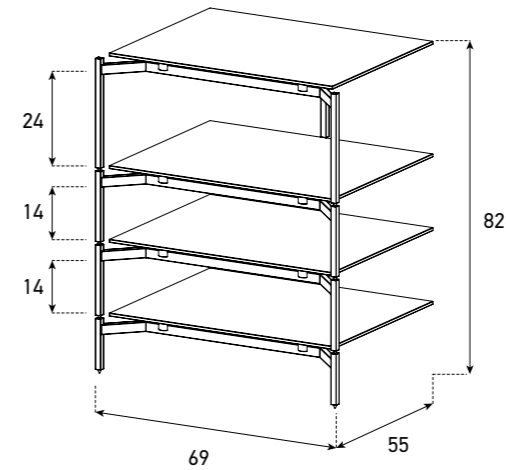

### RX 6040-VIC-HBLK

MAX TOP LOAD  
40 KG

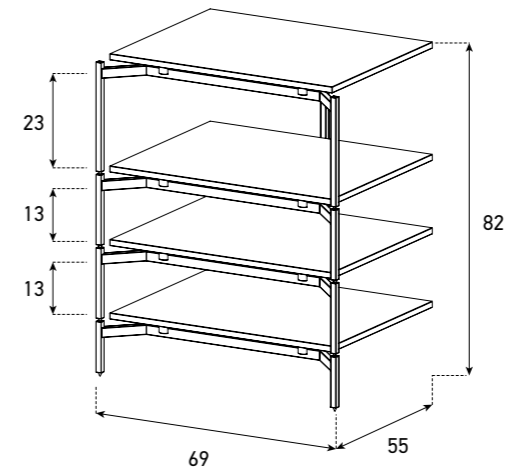

SP 100-B-HBLK

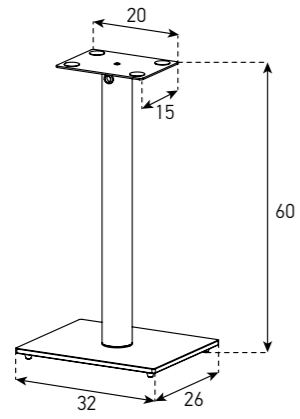

SP 300-B-HBLK



SP 100-WHT-WHT

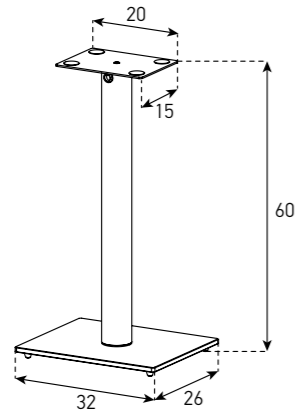

SP 500-BLK

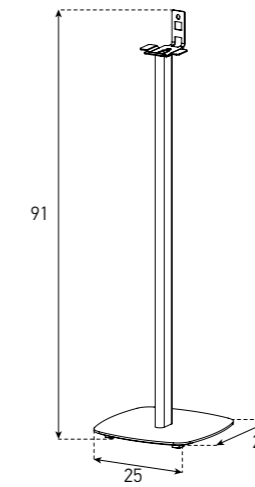

SP 200-B-SLV

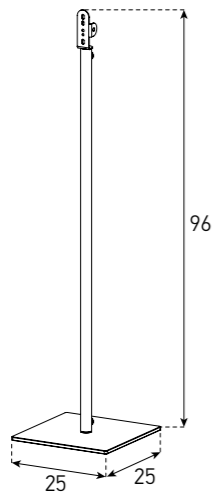

SP 600-B-HBLK

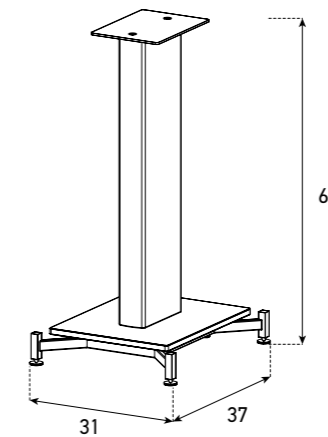



# PROFFESIONAL SERIES

## PR 2000

- 360° EASY-MOVE CASTORS (LOCKING OPTION)
- CABLE MANAGEMENT
- ADJUSTABLE HEIGHT WITH TELESCOPIC POLES (50 CM FLEXIBILITY)
- AV TRAY FOR ELECTRONIC DEVICES
- WIDE MOUNTING PATTERN, 90° ROTATION 2 OPTIONS FOR TV POSITION (LANDSCAPE /PORTRAIT)
- TV HEIGHT ADJUSTMENT MIN. 100 CM, MAX 150 CM.
- UPPER VIDEO TRAY SUPPORT (PROJECTOR / CONFERENCE CALL CAMERA)

## PR 2550

- TEMPERED GLASS WITH FLAT POLISHED EDGE
- RECTANGLE SHAPED ALUMINIUM
- INTEGRATED CABLE MANAGEMENT SYSTEM
- HIDDEN CASTERS
- (24°) SWIVEL SYSTEM
- ADJUSTABLE HEIGHT FOR BRACKET

PR 2000-N<sup>1</sup>  
PR 2550<sup>2</sup>

### ALUMINIUM COLORS

HBLK-HIGH GLOSS BLACK



INX-INOX



### GLASS COLORS

C-CLEAR



B-PIANOBLACK



### METAL COLORS

BLK-BLACK



## PR 2000-N

- MAX BRACKET LOAD  
45 KG
- IDEAL SCREEN SIZE  
65"

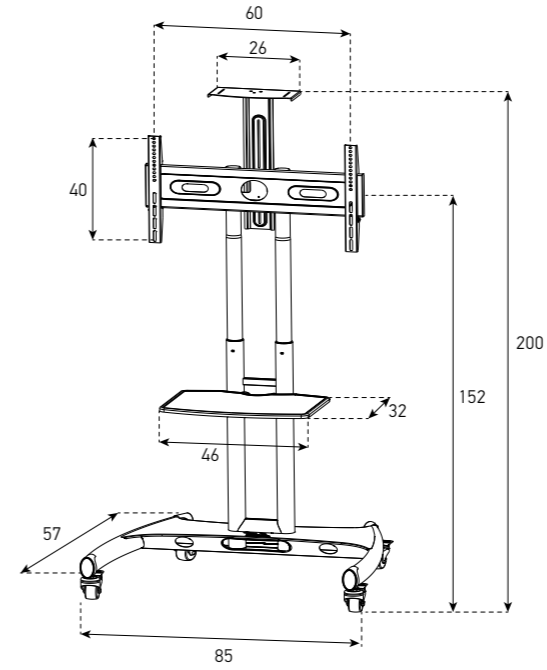

## PR 2550-B-HBLK

- MAX BRACKET LOAD  
50 KG
- IDEAL SCREEN SIZE  
50"

